

S  
Z  
T  
U

# 1D80.24

C



## M

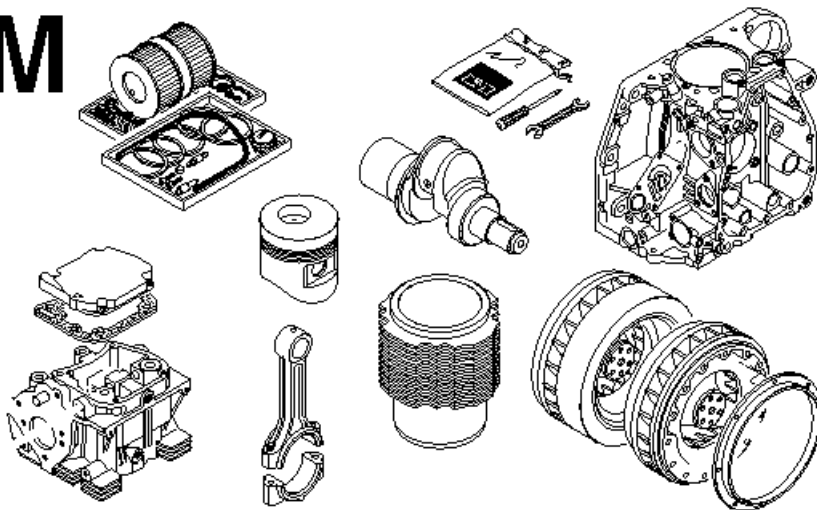

## A

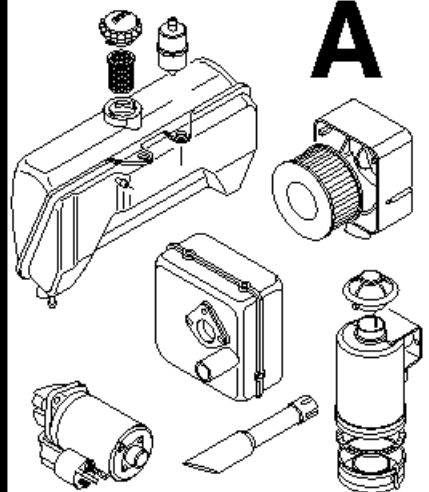

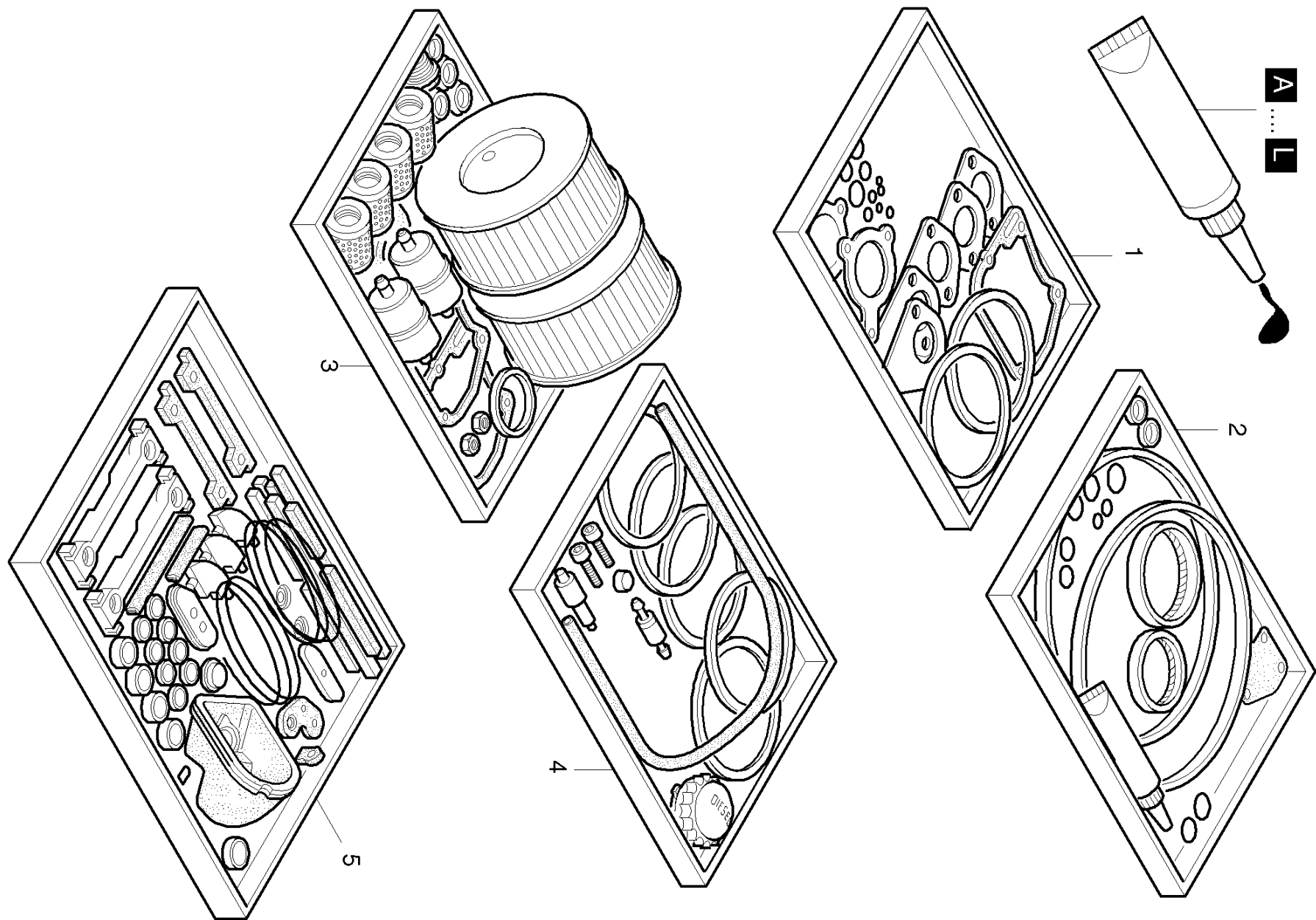

Pos.	Part no.	Description	Qty.	Notice	Add. notice	kg	EA	TA	DA	dDPW	List price
1	01249211	GASK.S.CYL.HD.1D80	1			0,180	1	12	0		191,737
2	01249311	GASK.S.CRANKC.60/90	1	part was replaced by 01249320		0,180	0	12	0		
3	01249410	MAINT.KIT 1D60/90 1	1			1,150	1	12	1		407,225
3	01292411	MAINT.KIT 1D60/90 3	1	without oil filter		0,928	1	12	1		313,4495
4	01249511	EMERGCY.KIT 1 D80 S	1			0,500	1	12	0		639,548
4	01293111	EMERGCY.KIT 1 D80 C	1			0,500	1	12	0		608,5625
5	01487900	RUBBER COMP.SET "C"	1	part was replaced by 01487901		0,000	0	12	0		
A	50223001	LOCTITE ACTIVATOR N	1	500 ML DIN 7649		0,580	4	12	0		270,7705
B	50223101	LOCTITE 574	1	50 ML		0,088	4	12	0		99,0535
C	50223200	LOCTITE 601	1	50 ML		0,079	4	12	0		99,0535
D	50223300	LOCTITE 221	1	50 ML		0,077	4	12	0		99,0535
E	50223400	LOCTITE 648	1	10 ML		0,021	4	12	0		38,6295
F	50223900	TECHNICOLL CLEANER	1	750 GR		0,870	4	12	0		101,2375
F	50223800	TECHNICL.ADHES.8058	1	750 GR		0,875	4	12	0		132,8145
G	50256501	LOCTITE IS 407	1	20 ML		0,033	4	12	0		52,143
H	50282501	SILICON SEALER	1	30ML 1207		0,055	4	12	1		48,23
J	50283004	HIGH TEMP.PASTE	1			0,110	4	12	0		71,617
K	50342600	GREASE START.DEVICE	1	100 GRAMM part was replaced by 50342601		0,100	0	12	0		
L	50256600	SILICON SEALER	1			0,130	4	12	0		193,4205
M	50485100	GRINDING PASTE 80ML	1			0,113	4	12	1		96,5055

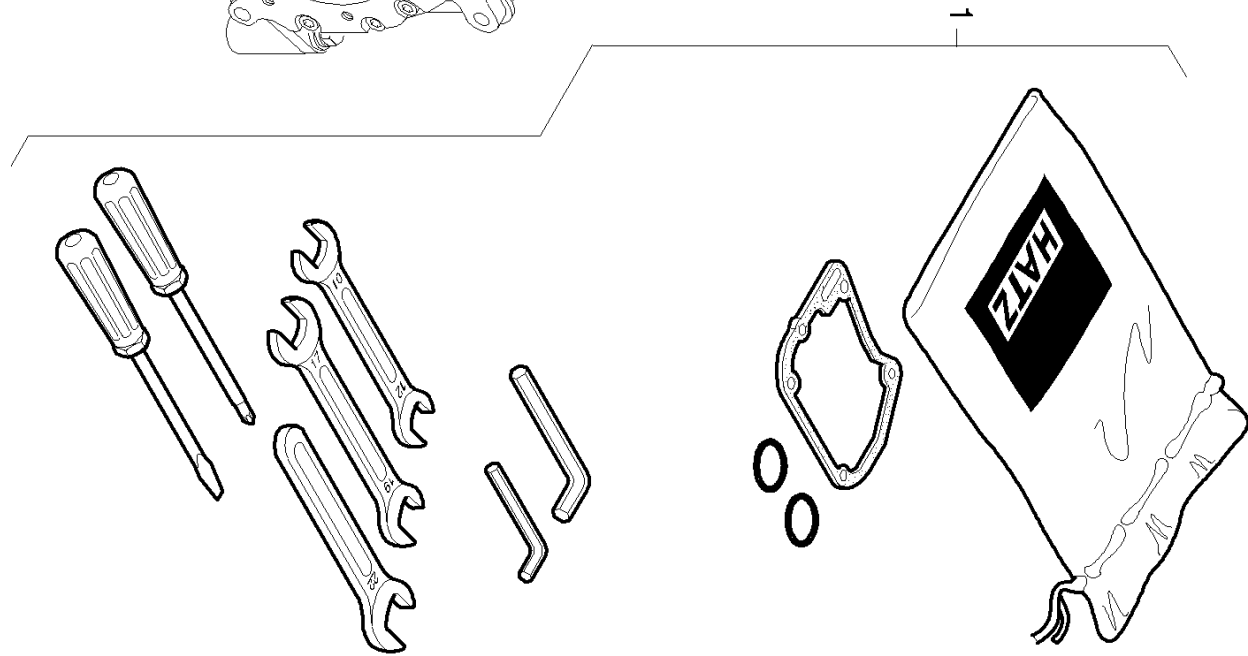
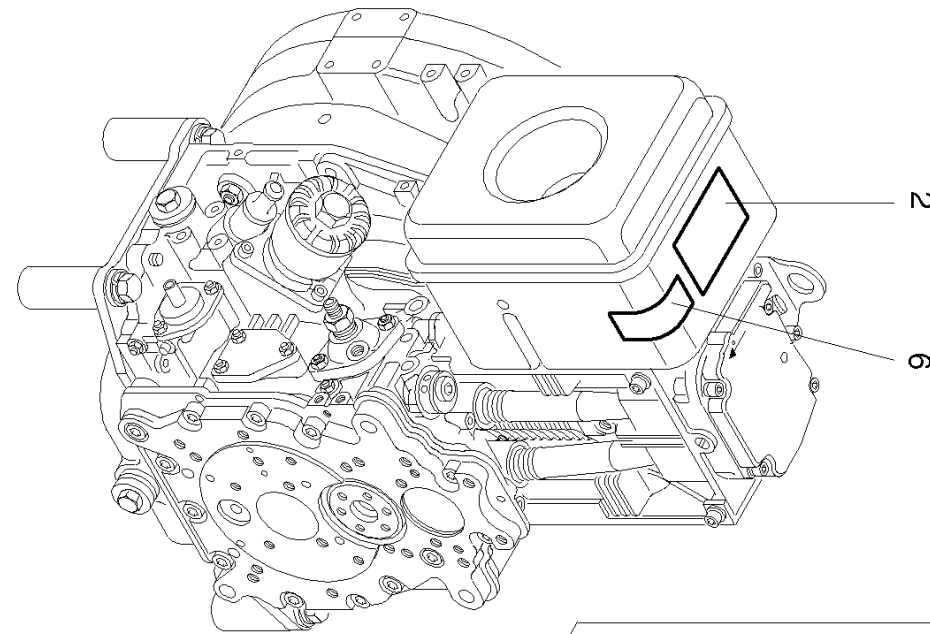
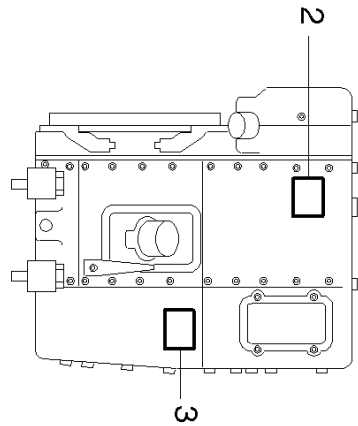
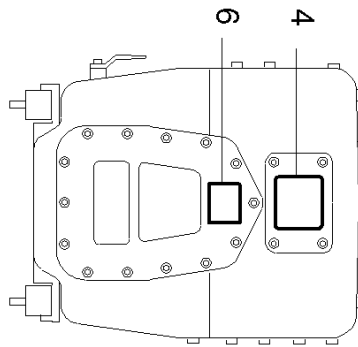
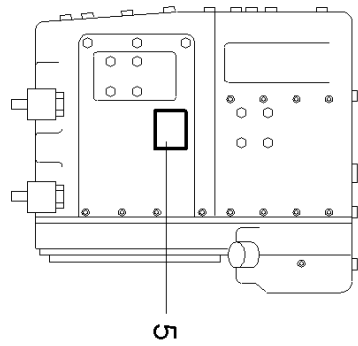



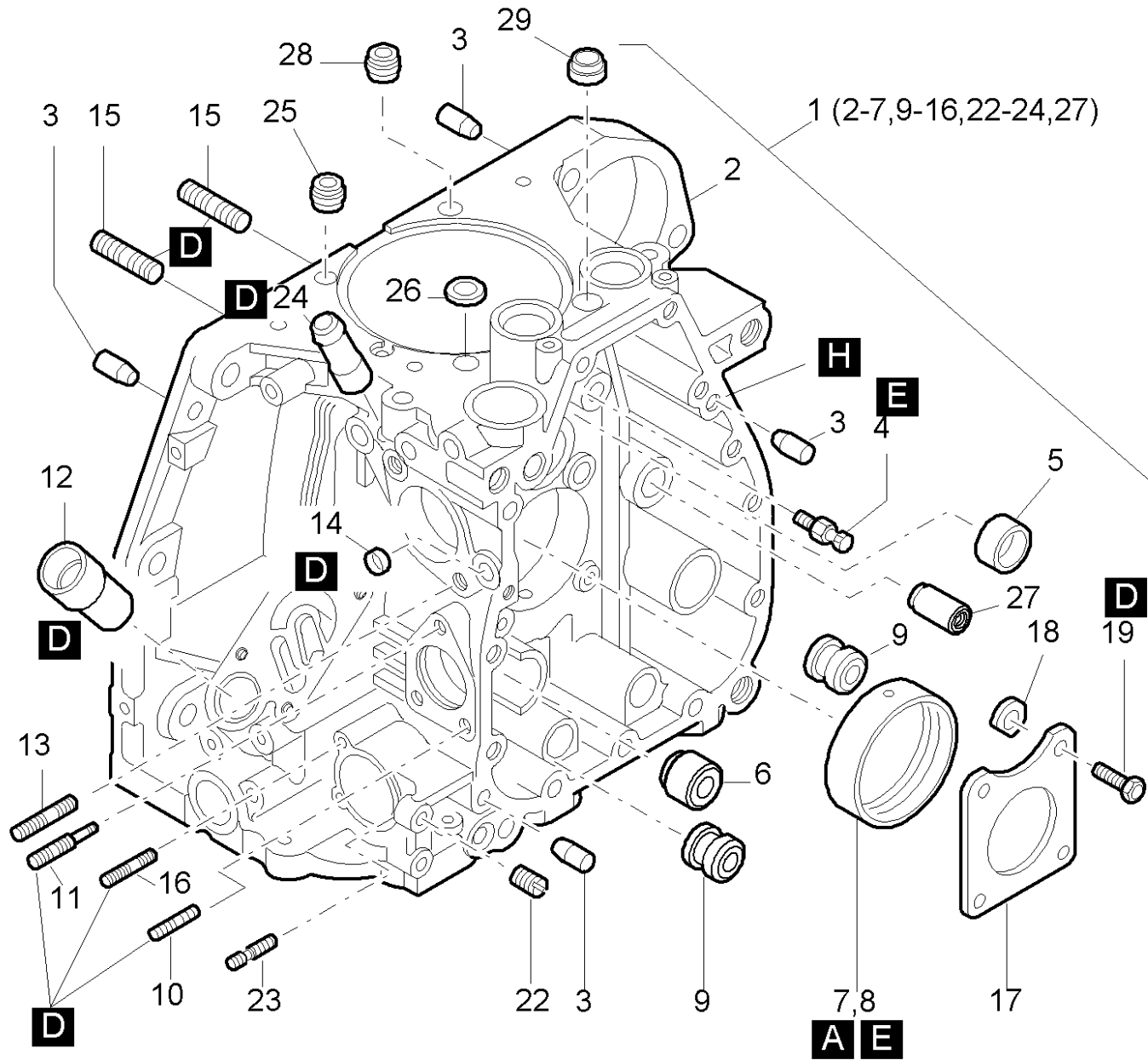

Pos.	Part no.	Description	Qty.	Notice	Add. notice	kg	EA	TA	DA	dDPW	List price
1	01249060	CRANKCASE 1D60/81	1	part was replaced by 01249061		0,000	0	12	7		
2	_noorder	No single order	-								
3	50249101	CYL.PIN 8M 6 X 20	4	8 M 6 x 20 DIN 6325 2-Fasen		0,005	9	11	7		3,9585
4	03793900	NOZZLE	1			0,005	1	11	1		18,20
5	03793800	BEARING BUSH	1			0,009	1	11	1		37,128
6	03794000	PLUG	0... 1	ø 22 mm		0,021	1	11	1		13,741
7	03793700	MAIN BEARING	1			0,080	4	11	1		119,028
8	04033700	MAIN BEARING 0,5 -	1	- 0,5 mm		0,086	4	14	1		175,812
9	04000800	PLUG	1...2	ø 22 mm		0,018	1	11	1		13,741
10	50144300	STUD M 6X 16	2	M 6 x 16 DIN 835 - 8.8 A3C		0,005	4	11	1		3,9585
11	03794510	STUD	1			0,007	1	11	1		14,1505
12	03794800	INTERMEDIATE PIECE	1			0,050	1	11	1		26,7085
13	50098300	STUD M8X20	2	M 8 x 20 DIN 835-8.8 A3C		0,009	4	11	1		5,3235
14	50325500	COVER 10	1	10 DIN 443-St A3C		0,001	4	11	1		1,4105
15	50037800	STUD M 8X 22	8	M 8 x 22 DIN 835-10.9		0,012	4	11	1		3,003
16	50328200	STUD M6X22	2	M 6 x 22 DIN 835 - 8.8 A3C		0,006	4	11	1		4,8685
17	04011650	THRUST PLATE	1	part was replaced by 04011651		0,000	0	11	7		
18	04069500	SHIM 1,05	0... 4	1,05 mm		0,001	1	11	1		3,185
18	04069600	SHIM 1,2	0... 4	1,20 mm		0,002	1	11	1		3,185
19	04062010	HEXSCREW M9 X 28	4	M 9 x28		0,017	1	11	1		9,191
22	_nopart	Not in this engine	-								
23	04087400	STUD M 6 X 22	1	M 6 x 22 A3C part was replaced by 50328200		0,005	0	11	7		
24	_noorder	No single order	-								
25	_nopart	Not in this engine	-								
26	_nopart	Not in this engine	-								
27	04105000	PLUG 15MM	1	ø 15 mm		0,010	1	11	1		10,7835
28	50459800	SEALING CYL. SCREW	2			0,002	4	11	1		10,3285
29	04084500	SEALING RING	2			0,001	1	11	1	d2	6,1425
A	50223001	LOCTITE ACTIVATOR N	1	500 ML DIN 7649		0,580	4	12	0		270,7705





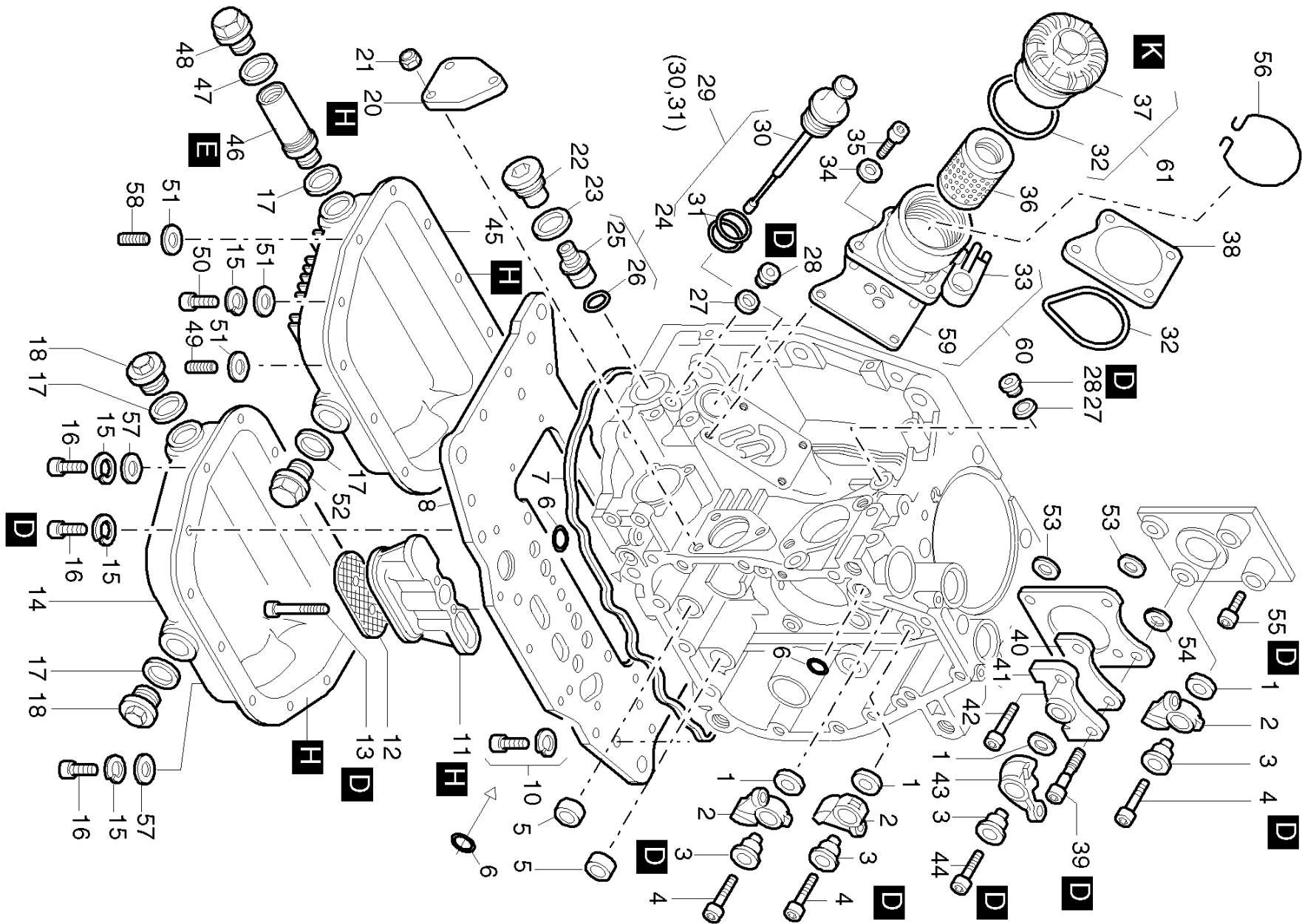

Pos.	Part no.	Description	Qty.	Notice	Add. notice	kg	EA	TA	DA	dDPW	List price
1	03794100	WASHER	2	10,1 x 22 x 3		0,006	1	11	1		10,4195
2	03794300	CAM FOLLOWER	2			0,040	1	11	1		166,621
3	03794201	CAM FOLLOW SPINDLE	2			0,018	1	11	1		40,3585
4	50051000	ALL.SCR.M 6X 30	2	M 6 x 30 DIN 912-8.8		0,009	4	11	1		1,729
5	03795800	O-RING 12X18,3X7,3	2	12 x 18,3 x 7,3		0,002	1	11	1	D1	12,8765
6	50329000	O-RING 9,5X2,5	3	9,5 x 2,5		0,001	4	11	1	D3	2,912
7	03795100	O-RING265X269,4X3,6	1	265 x 269,4 x 3,6		0,013	1	11	1	D1	82,7645
8	01248810	PLATE	1			3,400	1	12	1		563,6995
10	50417600	ALL.SCR. M 8X25 Z4	22	M 8 x 25 Z4 DIN 912-8.8 A3C		0,015	4	11	1		3,0485
11	03794900	HOUSING	1			0,151	1	11	1		42,133
12	03795000	SUCTION SIEVE	1			0,010	1	11	1		14,6965
13	50327100	ALL.SCR.M6X50	2	M6x50 DIN 6912-8.8 A3C		0,012	4	11	1		3,003
14	01241700	OIL SUMP	1			0,801	1	11	1		153,8355
15	50170900	SPRING WASHER 6	12	6 DIN 128 - A3C		0,001	4	11	1		0,455
16	50329100	ALL.SCR.M 6X10	12	M 6x10 DIN 912-8.8 Inbus Plus		0,005	4	11	1		2,5935
17	50001600	JOINT A22 X27	2	A 22 x 27 DIN 7603 Cu		0,002	4	11	1	D2,W4	2,2295
18	50140400	DRAIN PLUG M 22X1,5	0... 2	AM22x1,5DIN7604-5.8A3C		0,037	4	11	1		7,462
18	50373100	DRAIN PLG.MAGNT.M22	0... 2	AM22x1,5DIN7604A3C MAGN.		0,038	4	11	1	W1	29,575
20	03794700	COVER	1			0,118	9	11	0		10,8745
21	50328300	HEXAGON NUT VM6	3	VM 6 DIN 980-8 A3C		0,002	4	11	1		1,4105
22	01321200	CLOS.SCREW + SIEVE	1	M 24 x 1,5		0,052	1	11	1		39,039
23	50286400	JOINT A24X29	1	A 24 x 29 DIN 7603-Cu		0,003	4	11	1	D1	4,5955
24	01321100	OIL RELIEF VALVE	1			0,028	1	11	1		80,8535
25	_noorder	No single order	-								
26	50460400	O-RING 18 X 2	1	18 x 2		0,001	4	11	1	D1	2,912
27	50062400	JOINT A10 X13,5	2	A 10 x 13,5 DIN 7603-Cu		0,001	4	11	1	D2	0,364
28	50062300	CLOS.SCREW M10X1	2	M 10 x 1 DIN 908-5.8 A3C		0,005	4	11	1		4,3225
29	01241500	DIPSTICK	1			0,032	1	11	1		37,7195
30	_noorder	No single order	-								
31	50359700	O-RING 20,29X2,62	2	20,29 x 2,62		0,001	4	11	1	D2	6,643

Pos.	Part no.	Description	Qty.	Notice	Add. notice	kg	EA	TA	DA	dDPW	List price
32	50329200	RECTANG.RNG.50X55X3	2	50 x 55 x 3		0,002	4	11	1	D2,W1	11,4205
33	_noorder	No single order	-								
34	50081200	SPRING WASHER A 6	4	A 6 DIN 137 - A3C		0,001	4	11	1		0,455
35	50170600	ALL.SCR.M 6X 20	4	M 6 x 20 DIN 912-8.8 A3C		0,007	4	11	1		1,729
36	01480000	OILFILT.ELEM.1D....	1			0,060	4	12	1	W4	27,5275
37	_noorder	No single order	-								
38	04033401	COVER	1			0,105	1	11	1		38,9025
39	04053210	SET SCREW M 9	1			0,020	9	11	0		36,4455
40	_nopart	Not in this engine	-								
41	04024221	CAM FOLLOWER BRACK.	1			0,132	9	11	0		116,48
42	04062110	ALL.SCR.M 9X36	1	M 9 x 36		0,015	0	11	0		
43	04024301	CAM FOLLOWER T/U	1			0,040	9	11	0		260,988
44	50457900	ALL.SCR. M 6X 25	1	M 6 x 25 DIN 912 - 10.9		0,007	4	11	1		1,4105
45	04045800	OIL SUMP	1			0,992	1	11	1		380,8805
46	04046300	DRAIN EXTENSION	1	92 mm		0,198	1	11	1		79,4885
47	50001400	JOINT A18 X22	1	A 18 x 22 DIN 7603 - Cu		0,002	4	11	1		1,638
48	50044200	CLOS.SCREW M18X1,5	1	M 18 x 1,5 DIN 910		0,047	4	11	1		10,192
49	50434300	STUD M 8X 18	2	M 6 x 20 DIN 939-8.8 "C"		0,009	4	11	1		3,458
50	50050700	ALL.SCR.M 6X 16	8	M 6 x 16 DIN 912-8.8		0,005	4	11	1		1,729
51	50144500	FLAT WASHER 6,4	12	6,4 DIN 125-St A3C		0,001	4	11	1		0,455
52	50140400	DRAIN PLUG M 22X1,5	1	AM22x1,5DIN7604-5.8A3C		0,037	4	11	1		7,462
53	04069600	SHIM 1,2	0... 3	1,20 mm		0,002	1	11	1		3,185
53	04069500	SHIM 1,05	0... 3	1,05 mm		0,001	1	11	1		3,185
54	04069900	SHIM 1,20	0... 1	1,20 mm		0,002	9	11	0		3,4125
54	04069800	SHIM 1,05	0... 1	1,05 mm		0,001	9	11	0		3,4125
55	04065400	ALL.SCR. M 6 X 12	1	M 6 X 12 part was replaced by 04065401		0,000	0	11	7		
56	04084000	LIFTING SPRING	1	part was replaced by 04084001		0,000	0	21	7		
57	_nopart	Not in this engine	-								
58	50139200	STUD M 6X 16	2	M 6 x 16 DIN 939-8.8		0,002	4	11	0		1,4105





**\_090.24\_TM02M03 M02 Crankshaft, bearing flange 1 D 80.24**

CD-ID: 001M1

Pos.	Part no.	Description	Qty.	Notice	Add. notice	kg	EA	TA	DA	dDPW	List price
1	01269810	CRANKSHFT.1D60-1D90	1	part was replaced by 01269820		4,400	0	11	0		
2	_noorder	No single order	-								
3	50087200	COVER 28	1	28 DIN 443		0,011	4	11	1		4,8685
4	03796000	COUNTER WEIGHT	1			1,075	1	11	1		97,3245
5	50055000	ALL.SCR.M10X 50	2	M 10 x 50 DIN 912-10.9		0,043	9	11	0		4,8685
6	50362600	FITTINGKEY A 6X4X32	1	A 6 x 4 x 32 DIN 6885 St 60		0,006	4	11	1		2,6845
7	03796120	GEARWHEEL F. CRANKS	1			0,225	1	11	1		455,5005
8	04000600	BUFFER RING	1			0,026	1	11	1		62,1075
9	50224900	O-RING 123X 2,5	1	123 x 2,5		0,003	4	11	1	D1	14,196
11	04064201	BEARING FLANGE	1			3,175	1	11	0		566,9755
12	04006800	MAIN BEARING	1			0,080	4	11	1		119,119
13	04036100	MAIN BEARING 0,5 -	1	- 0,5 mm		0,083	4	14	1		175,812
14	50362701	OIL SEAL 62X 90X10	1	62 x 90 x 10		0,053	4	11	1	D1	68,6595
15	50413600	WASHER 8,4	8	8,4 300 HV DIN 125A-A3C		0,001	4	11	1		1,092
16	50364300	HEXAGON NUT M 8	8	M 8 DIN 934 - 10.9 A3C		0,005	4	11	1		1,729
17	04023110	STUBSHAFT SAE CYL.	1	SAE ...2 ø 1" zyl., cyl. part was replaced by 04023120		0,660	0	11	7		
18	01485500	STUBSHAFT SAE TAPER	1	SAE ...4 ø 1" keg.		0,700	1	11	1		606,1965
19	04022910	STUBSHAFT ITALIA	1	ITAL. ...3 ø 30 mm tap.		0,445	1	11	1		855,8095
20	05033200	STUB SHAFT ITAL. 23	1	ITAL. ...6 ø 23 mm con.		0,400	1	11	1		603,876
21	05141600	FITTINGKEY 6,35X61	1	A 6,35 x 61		0,018	1	11	1		6,279
22	50017800	WOODRUFF KEY 4X6,5	1	4 x 6,5 DIN 6888		0,003	4	11	1		1,729
23	50414400	WEAR SLEEVE 62X12,7	0... 1			0,050	4	12	0		306,8065
24	01512001	REP.SET CKRSH.60-81	1	part was replaced by 01512002		5,522	0	12	7		
25	_nopart	Not in this engine	-								
E	50223400	LOCTITE 648	1	10 ML		0,021	4	12	0		38,6295

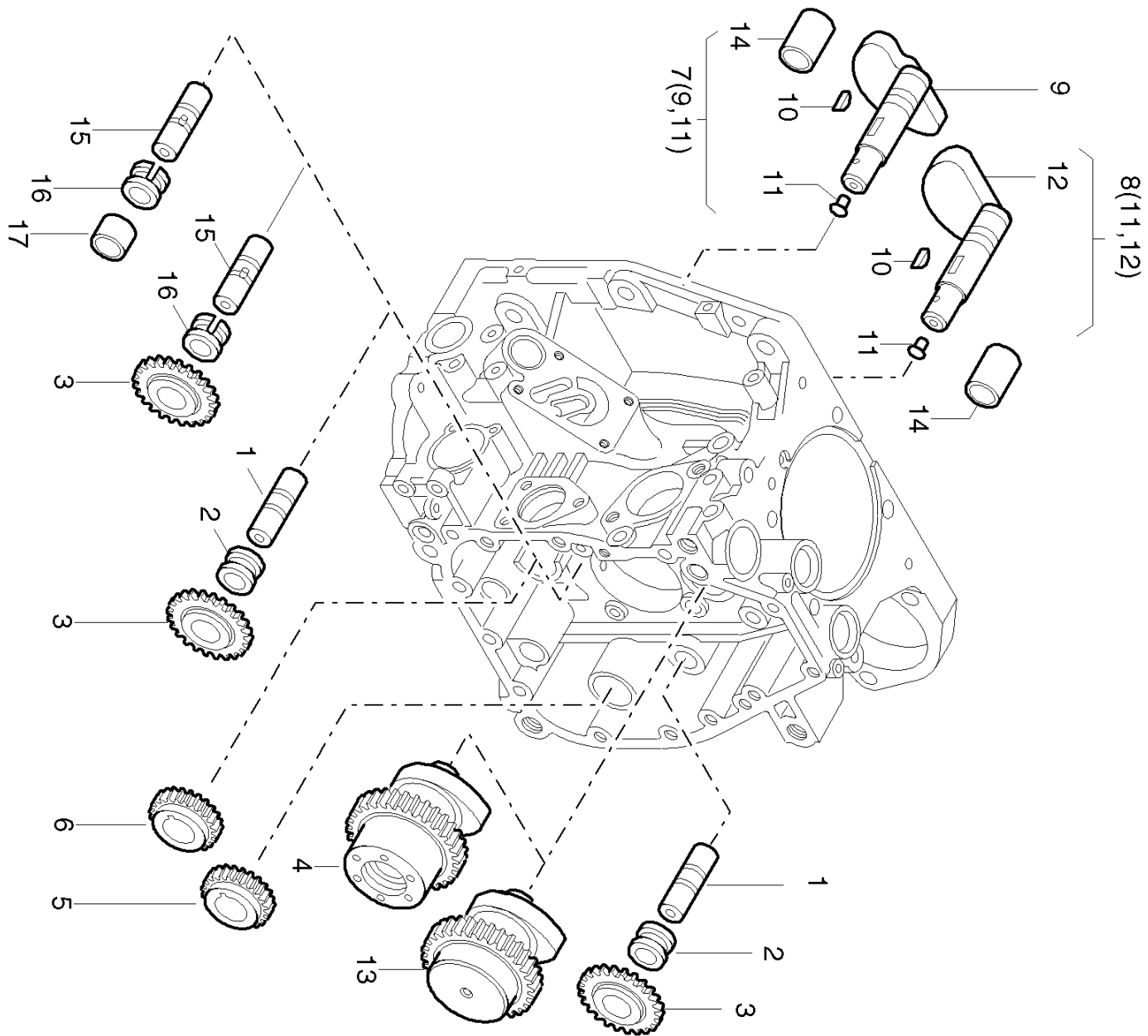

**\_090.24\_TM04 M04 Camshaft, Compensation of masses 1 D 80.24**

CD-ID: 001M1

Pos.	Part no.	Description	Qty.	Notice	Add. notice	kg	EA	TA	DA	dDPW	List price
1	03796401	SHAFT	2			0,072	1	11	1		53,9175
2	03796500	BUSH	2			0,028	1	11	1		21,7945
3	01242000	GEARWHEEL	2			0,176	1	11	1		319,5465
4	03797020	CAMSHAFT L	1			1,250	1	11	0		866,8205
5	03796800	GEARWHEEL	1	Z, U, C		0,107	1	11	1		275,4115
6	03796900	GEARWHEEL	1	Z, U, C		0,107	1	11	1		275,6845
7	01267300	SHAFT PUMP SIDE	1			0,718	1	12	0		437,528
8	01267200	SHAFT STARTER SIDE	1			0,718	1	12	0		437,528
9	_noorder	No single order	-								
10	50324900	WOODRUFF KEY 3X3,7	2	3 x 3,7 DIN 6888 St 60 Z, U, C		0,001	4	11	1		2,3205
11	_noorder	No single order	-								
12	_noorder	No single order	-								
13	04022200	CAMSHAFT R	1			1,250	9	11	0		723,6775
14	_nopart	Not in this engine	-								
15	01320700	SHAFT	1			0,080	1	11	1		50,96
16	04107600	BUSH	1			0,005	1	11	1		8,4175
17	04011900	BUSH	1	15x24x17		0,050	1	11	1		12,9675



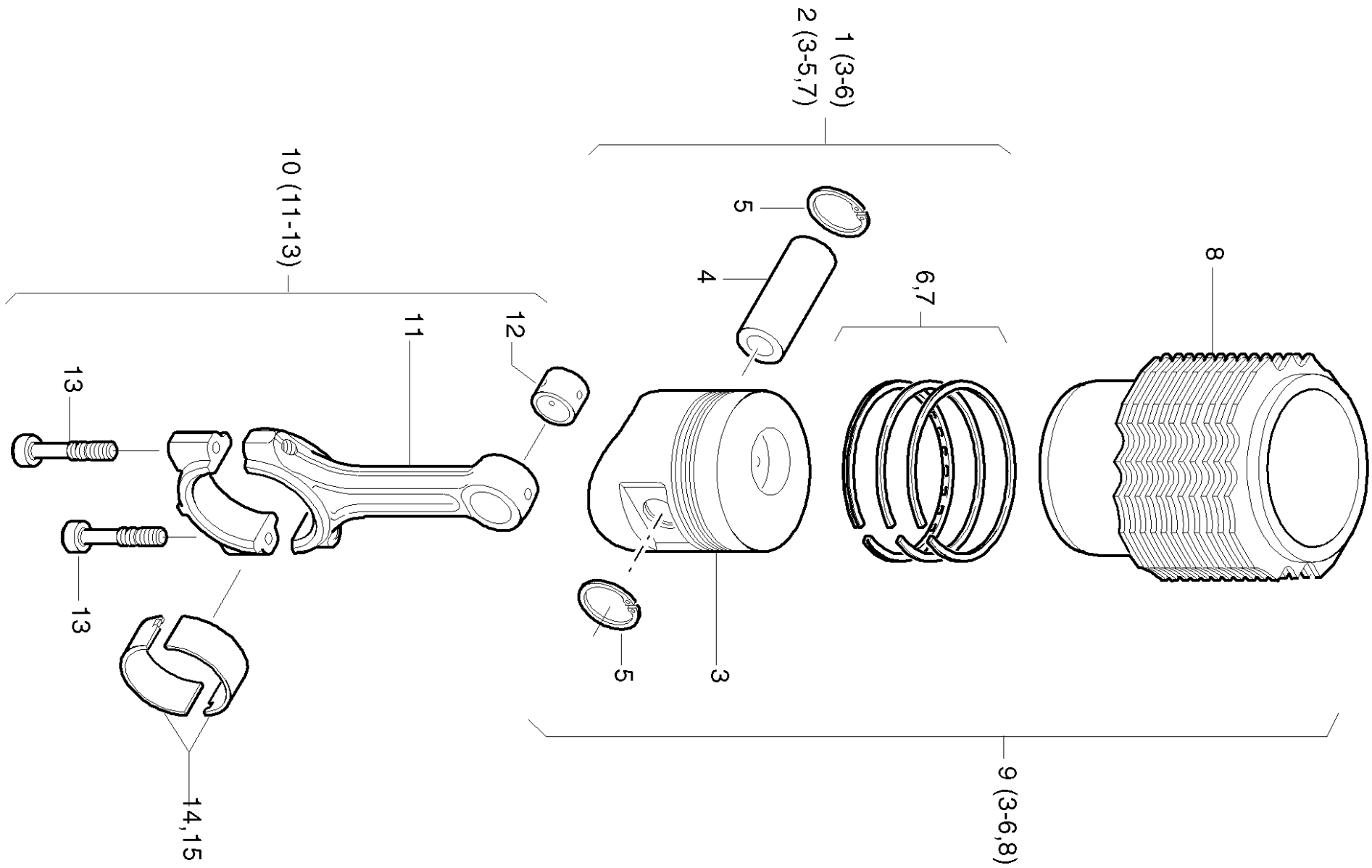

Pos.	Part no.	Description	Qty.	Notice	Add. notice	kg	EA	TA	DA	dDPW	List price
1	01243901	PISTON 100	1			1,180	4	11	0		713,8495
2	01265201	PISTON 100 + 1,0	1			1,280	4	14	0		985,803
2	01265101	PISTON 100 + 0,5	1			1,227	4	14	0		985,803
3	_noorder	No single order	-								
4	50353600	GUDGEON 30X17X75	1	30 x 17 x 75		0,283	4	13	1		111,7935
5	50020800	CIRCLIP 30X1,2	2	J 30 x 1,2 DIN 472		0,003	4	11	0		2,457
6	01247300	PISTON RING SET 100	1			0,062	4	13	1		172,9455
7	01264500	PIST.RNG.SET100+0,5	1	+ 0,5 mm		0,075	4	14	1		181,454
7	01265000	PISTON RING SET 101	1	+ 1,0 mm		0,075	4	14	1		212,3485
8	_noorder	No single order	-								
9	01249100	CYLINDER WITH PIST.	1			5,180	1	12	0		1509,599
10	01244010	CONROD	1	part was replaced by 01244001		0,925	0	11	7		
11	_noorder	No single order	-								
12	04032210	BUSH FOR CONROD	1			0,050	4	12	0		74,0285
13	04001810	CONROD SCREW	2			0,038	1	11	1		19,474
14	04001900	BIG END BEARING	1			0,040	4	11	1		63,2905
15	04033100	BIG END BEAR.0,5 -	1	- 0,5 mm		0,046	4	14	1		85,267

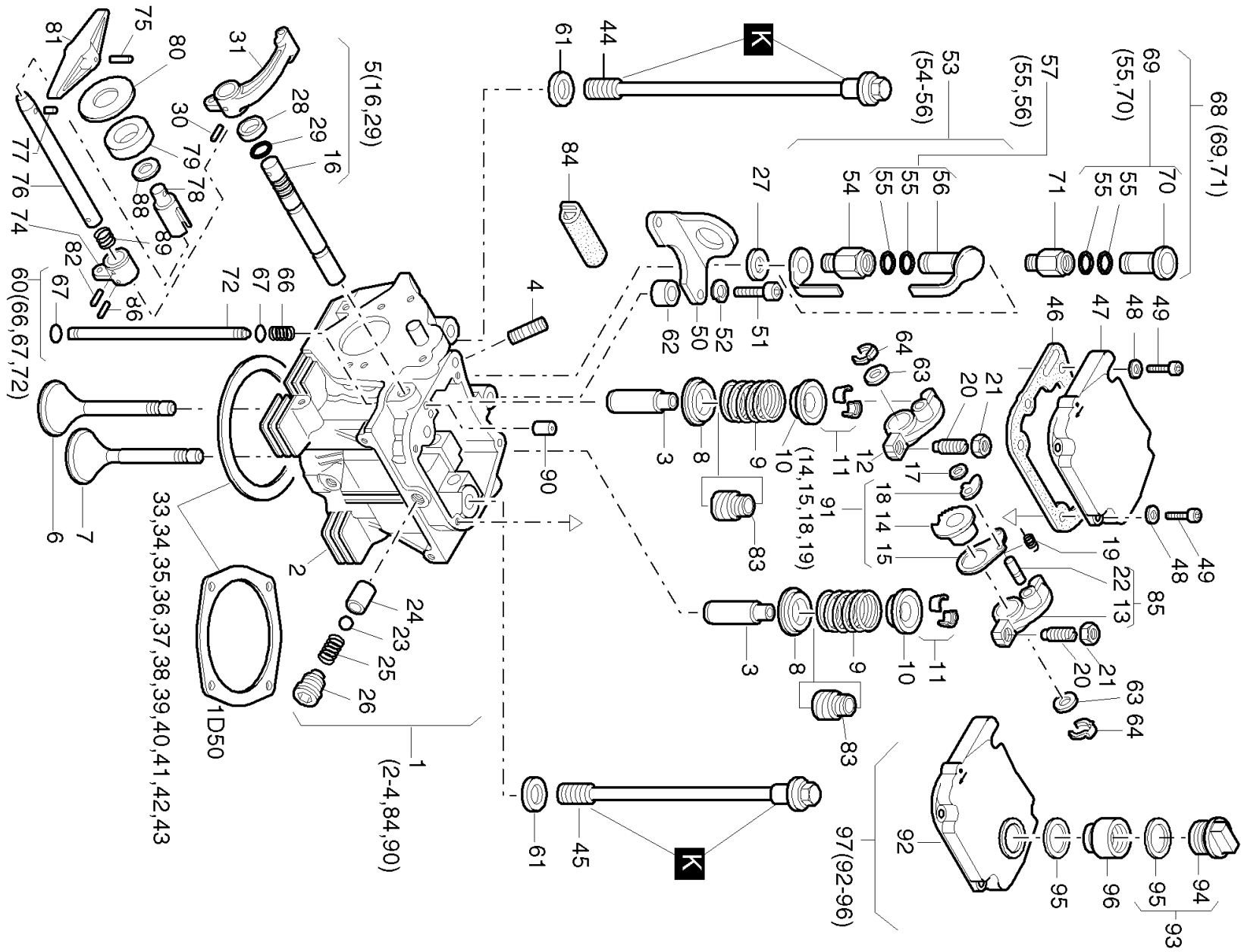

Pos.	Part no.	Description	Qty.	Notice	Add. notice	kg	EA	TA	DA	dDPW	List price
1	01264810	CYLINDER HEAD 1D80	1			3,800	9	12	0		1426,6525
2	_noorder	No single order	-								
3	04008711	VALVE GUIDE	2	part was replaced by 04008712		0,052	0	12	7		
4	50038400	STUD M 8X 35	1	M 8 x 35 DIN 835-8.8 A3C		0,017	4	11	1		5,0505
5	01468910	ROCKER SHAFT 60/80	1	IMT 96553		0,115	1	11	0		208,3445
6	04005001	VALVE INLET	1			0,100	9	11	0		72,5725
7	04005101	VALVE EXHAUST	1			0,095	9	11	0		89,089
8	04005201	WASHER	2			0,015	1	11	1		17,1535
9	04005300	VALVE SPRING	2			0,041	1	11	1		17,5175
10	04005401	CUP	2			0,018	1	11	1		32,3505
11	03786300	COLLET	2			0,003	1	11	1		11,2385
12	04003710	ROCKER INLET	1			0,055	1	11	1		177,996
13	_noorder	No single order	-								
14	_noorder	No single order	-								
15	03778401	SPRING SHEET	1			0,002	1	11	1		2,821
16	_noorder	No single order	-								
17	50117200	CIRCLIP	1	RA 4ME DIN 6799		0,001	4	11	1		0,455
18	03365710	RATCHET F.DECOMPR.	1			0,004	1	11	1		30,303
19	03366001	SPRING	1			0,001	1	11	1		5,5965
20	03783000	ADJUSTING SCREW	2			0,008	1	11	1		18,928
21	03173100	HEXAGON NUT	2			0,004	1	11	1	W2	5,1415
22	_noorder	No single order	-								
23	50123800	BALL 7 MM G100	1	7 mm III DIN 5401		0,001	4	11	1		2,002
24	04004700	BUSH	1			0,016	1	11	1		45,864
25	04004800	PRESSURE SPRING	1			0,003	1	11	1		3,6855
26	01245200	ADJUSTING SCREW	1			0,005	1	11	1		32,214
27	50001100	JOINT A12 X15,5	1	A 12 x 15,5 DIN 7603-Cu		0,001	4	11	1	d1	0,7735
28	04048900	RUBBER RING	1	12 x 18 x 5		0,001	1	11	1	d1	3,276
29	40022401	O-RING 8 X 2 GRAY	1...2	8 x 2 FPM 75 MOLYKOT.		0,002	4	11	1	d2	1,911
30	50034700	PIN 4 X22	1	4 x 22 ISO 8752-ST		0,002	4	11	1		1,4105

Pos.	Part no.	Description	Qty.	Notice	Add. notice	kg	EA	TA	DA	dDPW	List price
31	04009810	HANDLE	1			0,015	1	11	1		9,6005
33	_nopart	Not in this engine	-								
34	_nopart	Not in this engine	-								
35	04068800	GASK.F.CYL.HEAD 0,5	0... 1	0,5 mm		0,015	1	11	1		18,20
36	04036800	GASK.F.CYL.HEAD 0,6	0... 1	0,6 mm		0,016	1	11	1		18,746
37	04036500	GASK.F.CYL.HEAD 0,7	0... 1	0,7 mm		0,018	1	11	1	d1	19,1555
38	04036600	GASK.F.CYL.HEAD 0,8	0... 1	0,8 mm		0,021	1	11	1	d1	21,385
39	04002700	GASK.F.CYL.HEAD 0,9	0... 1	0,9 mm		0,023	1	11	1	d1	23,1595
40	04002800	GASK.F.CYL.HEAD 1,0	0... 1	1,0 mm		0,026	1	11	1		25,0705
41	04002900	GASK.F.CYL.HEAD 1,1	0... 1	1,1 mm		0,029	1	11	1		26,39
42	04003000	GASK.F.CYL.HEAD 1,2	0... 1	1,2 mm		0,031	1	11	1		28,756
43	04003100	GASK.F.CYL.HEAD 1,3	0... 1	1,3 mm		0,034	1	11	1		30,303
44	04003200	CYL.HEAD SCREW305MM	2	305 mm		0,190	1	11	1		68,614
45	04003300	CYL.HEAD SCREW258MM	2	258 mm		0,165	1	11	1		59,878
46	04006111	GASKET	1			0,003	1	11	1	d1,W3	10,01
47	01245413	COVER CYL.HEAD	1			0,245	1	11	5		121,94
48	50081200	SPRING WASHER A 6	4	A 6 DIN 137 - A3C		0,001	4	11	1	P4	0,455
49	50170800	ALL.SCR.M 6X 25	4	M 6 x 25 DIN 912 - 8.8 A3C		0,008	4	11	1	P2	1,8655
50	04008100	LIFTING BRACKET	1			0,071	1	11	1		41,496
51	50366300	ALL.SCR.M 8X 20	2	M 8 x 20 DIN 912-8.8 A3C		0,013	4	11	1		2,3205
52	50208500	SPRING WASHER 8	2	8 DIN 128 A3C		0,001	4	11	1		1,4105
53	01493200	OIL FIL.DEV."S"46MM	1			0,080	1	12	1		53,8265
54	_noorder	No single order	-								
55	40081700	O-RING 12 X 16X 2	2	12 x 2		0,001	4	11	1	d2	2,3205
56	_noorder	No single order	-								
57	01308300	CLOSG.PLUG "S"46MM	1	part was replaced by 01308301		0,012	0	11	7	P1	
60	01269700	OIL PRESSURE PIPE	1			0,048	1	11	1		38,0835
61	03457500	DISC F.STUD	4	12,5 x 24 x 2,5		0,006	1	11	1		7,553
62	_nopart	Not in this engine	-								
63	_nopart	Not in this engine	-								

Pos.	Part no.	Description	Qty.	Notice	Add. notice	kg	EA	TA	DA	dDPW	List price
64	_nopart	Not in this engine	-								
66	04004200	PRESSURE SPRING	2			0,001	1	11	1		1,7745
67	50330100	O-RING 4X 1,2	2	4 x 1,2		0,001	4	11	1	d2	1,001
68	01280600	OIL FILLER DEVICE	1			0,080	1	12	1		71,2075
69	01275610	CLOSG.PLUG "C" 46MM	1	part was replaced by 01275611		0,016	0	11	7	P1	
70	_noorder	No single order	-								
71	_noorder	No single order	-								
72	_noorder	No single order	-								
74	04047920	INTERM.PIECE DECOMP	1			0,035	1	21	4		148,239
75	50132000	ROLL PIN 4X16	1	4 x 16 ISO 8752-ST		0,002	4	11	1		1,4105
76	04048220	DECOMPR. SHAFT "C"	1			0,056	1	21	4		68,3865
77	50034500	PIN 4 X14	1	4 x 14 ISO 8752-ST		0,001	4	11	2		1,4105
78	04048110	INTERMEDIATE PIECE	1			0,022	1	21	4		67,2035
79	01581600	DOUBLE SEALG.RINGS	1			0,002	1	21	4		18,655
80	04048000	WASHER 10,5X50X0,8	1	10,5x50x1,0		0,002	1	21	4		4,459
81	03778200	HANDLE	1			0,010	1	21	4		11,7845
82	50132000	ROLL PIN 4X16	1	4 x 16 ISO 8752-ST		0,002	4	11	1		1,4105
83	50405200	VALVE STEM SEAL CAP	2			0,002	4	11	1	d2	8,099
84	_nopart	Not in this engine	-								
85	01285010	ROCKER EXHAUST	1			0,065	1	12	1		158,977
86	50034600	PIN 4 X18	1	4 x 18 ISO 8752-ST		0,002	4	11	2		1,4105
88	03787300	SHIM 0,2	1	10,5 x 21 x 0,2		0,001	1	11	1		4,823
89	04097200	PRES.SPRING DECOMPR	1			0,001	1	21	4		7,007
90	04038500	PLUG	1			0,001	1	11	0		2,002
91	01557600	GEARWHEEL F.DECOMPR	1			0,040	1	12	1		147,5565
92	01286610	COVER F. CYL.HEAD	1	part was replaced by 01286611		0,230	0	21	7		
93	01613100	CAP SCREW	1			0,017	1	11	1		13,104
94	_noorder	No single order	-								
95	04125000	SEALING RING	1	26 x 35 x3		0,002	1	11	1		3,8675
96	03658400	INTERMEDIATE PIECE	1			0,030	1	11	4		39,039



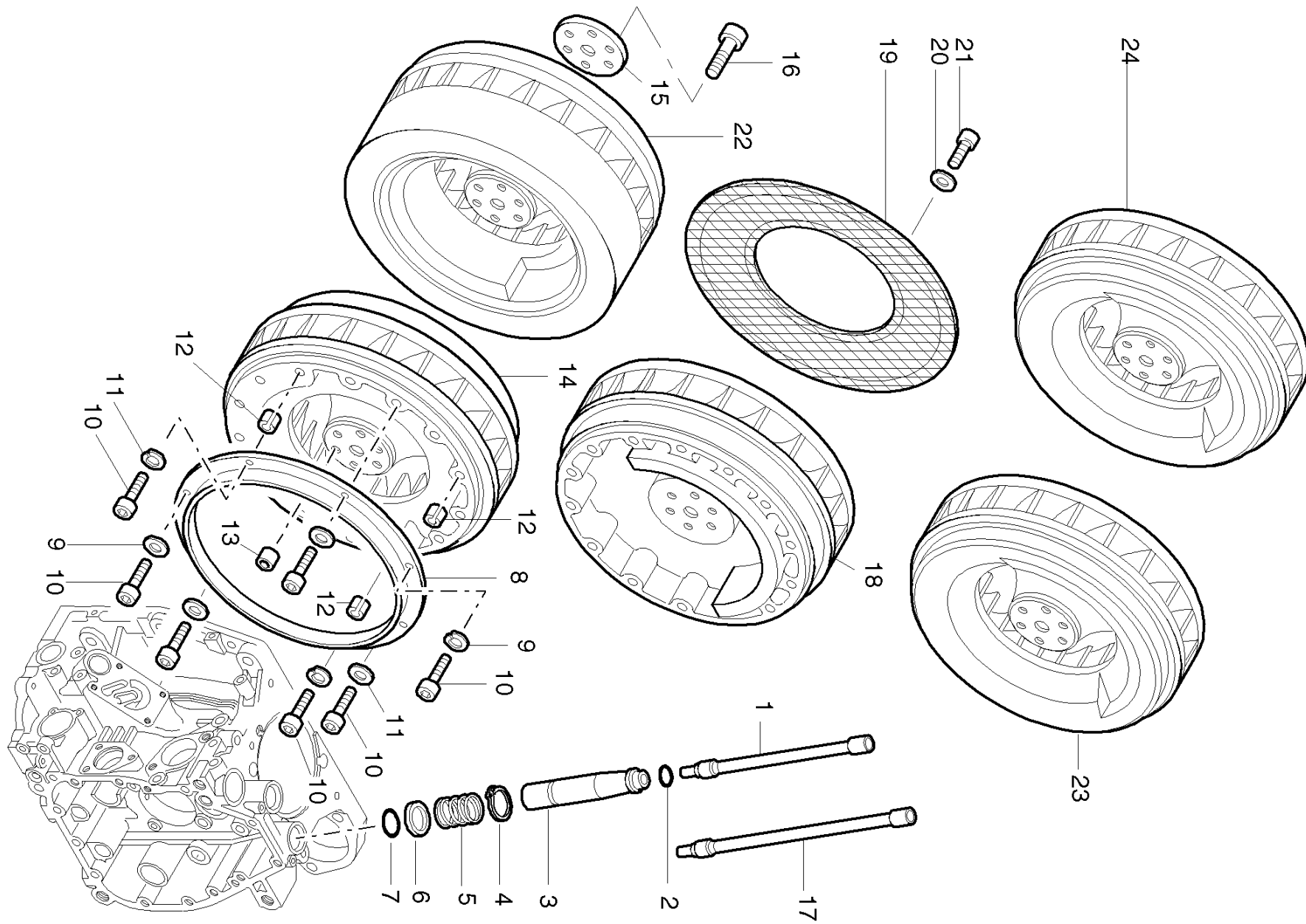



Pos.	Part no.	Description	Qty.	Notice	Add. notice	kg	EA	TA	DA	dDPW	List price
1	01244310	PUSHROD	2			0,061	1	11	1		123,942
2	50330200	O-RING 19X3 N	2	19 x 3		0,001	4	11	1	d2	4,1405
3	04002500	PROTECTION TUBE	2			0,083	1	11	1		39,039
4	50347000	CIRCLIP AS 24X1,75	2	AS 24 x 1,75 DIN 471		0,002	4	11	1	P2	6,0515
5	04002600	PRESSURE SPRING	2			0,015	1	11	1		9,737
6	04002000	PRESSURE RING	2			0,003	1	11	1		2,912
7	50330300	O-RING 23X3	2	23 x 3		0,002	4	11	1		5,096
8	04007500	RING F.FLYWHEEL	1			0,183	1	11	1		42,497
9	_nopart	Not in this engine	-								
10	50397100	ALL.SCR.M 4 X 10	7	M 4 x 10 DIN 912-8.8 A3C Tuf.		0,002	4	11	1		2,3205
11	_nopart	Not in this engine	-								
12	_nopart	Not in this engine	-								
13	03123700	BUSH	1			0,004	1	11	1		8,4175
14	04007131	FLYWHEEL S/Z/C	1	part was replaced by 04007132		0,000	0	11	7		
15	04007410	PLATE	1			0,030	1	11	1		18,473
16	50363100	ALL.SCR.M12X1,5X 40	6	M 12 x 1,5 x 40 DIN 912-10.9		0,047	4	11	1		6,0515
17	01257710	PUSHROD T/U	1			0,070	1	11	0		135,772
18	04024120	FLYWHEEL T/U ITALIA	1	part run out no successor		0,000	0	11	7		
19	01301300	PROTECTION SCREEN	1			0,170	0	11	0		
20	50144500	FLAT WASHER 6,4	6	6,4 DIN 125-St A3C		0,001	4	11	1		0,455
21	50025400	HEXSCREW M 6X 10	6	M 6 x 10 DIN 933 - 8.8 A3C		0,004	4	11	1		1,729
22	04074502	FLYWHEEL CR.HAND.ST	1			37,000	0	21	7		
23	_nopart	Not in this engine	-								
24	_nopart	Not in this engine	-								

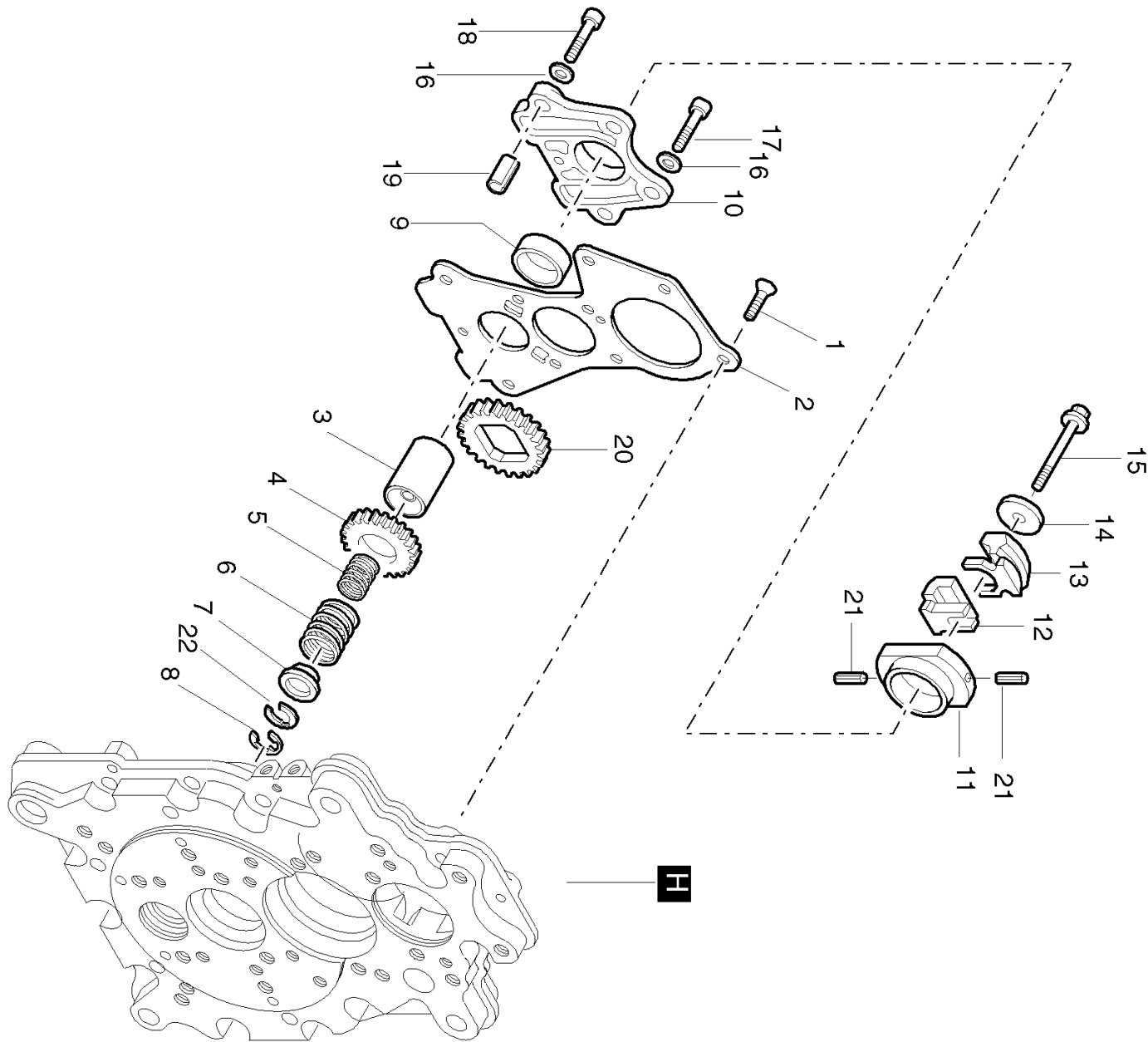

Pos.	Part no.	Description	Qty.	Notice	Add. notice	kg	EA	TA	DA	dDPW	List price
1	50328000	CTR.SUNK SCR.AM6X16	5	AM 6 x 16 17065 - 8.8 Zn		0,004	4	11	1		2,6845
2	03797412	COVER F. OIL PUMP	1			0,226	1	11	1		112,0665
3	01242401	SPRING CAPSULE+BUSH	1			0,090	1	11	1		187,9605
4	03797310	GEARWHEEL	1			0,056	1	11	1		148,5575
5	04008801	GOVERNOR SPRING 1,9	0... 1	ø 1,9 mm 1801...2300 min-1		0,006	1	11	1		11,6025
5	04052900	GOVERNOR SPRING 1,7	0... 1	ø 1,7 mm 1501...1800 min-1		0,006	1	11	1		12,649
5	04052800	GOVERNOR SPRING 1,6	0... 1	ø 1,6 mm ... 1500 min-1		0,006	1	11	1		12,0575
6	04089600	GOVERNOR SPRING 2,8	0... 1	ø 2,8 mm 3000 min-1 Gen.PV78		0,020	1	11	1		54,2815
6	04063400	GOVERNOR SPRING 2,8	0... 1	ø 2,8 mm 2301...3000 min-1		0,016	1	11	1		20,2475
6	04070800	GOVERNOR SPRING 2,6	0... 1	ø 2,6 mm 2301...2500 min-1		0,015	1	11	1		19,292
7	03798600	CUP	1			0,005	1	11	1		13,104
8	50334700	CIRCLIP 5	1	5 ME DIN 6799		0,001	4	11	1		0,455
9	03797600	BEARING BUSH	1			0,009	9	11	0		29,12
10	03797510	HOUSING FOR OILPUMP	1	part was replaced by 01869300		0,078	0	11	0		
11	03797701	PLATE CENTRIF.WEIGH	1			0,085	1	11	1		136,409
12	03798002	CENTRIFUGAL WEIGHT	1			0,056	1	11	1		94,549
13	03798102	CENTRIFUGAL WEIGHT	1			0,055	1	11	1		94,549
14	03797900	WASHER	1			0,008	1	11	1		24,661
15	03797801	PIN	1			0,016	1	11	1		49,049
16	50081200	SPRING WASHER A 6	5	A 6 DIN 137 - A3C		0,001	4	11	1		0,455
17	50170800	ALL.SCR.M 6X 25	3	M 6 x 25 DIN 912 - 8.8 A3C		0,008	4	11	1		1,8655
18	50051000	ALL.SCR.M 6X 30	2	M 6 x 30 DIN 912-8.8		0,009	4	11	1		1,729
19	50084901	PIN 8 X 12	2	8 x 12 DIN 7346 55 Si 7 2Fasen		0,003	4	11	1		1,4105
20	03798720	GEARWHEEL	1			0,061	1	11	1		136,955
21	50260501	ROLL PIN 2X10	2	2 x 10 ISO 8752-ST		0,001	4	11	1		1,0465
22	04046000	CIRCLIP	0... 3	0,5 mm		0,001	1	11	1		2,3205
H	50282501	SILICON SEALER	1	30ML 1207		0,055	4	12	1		48,23

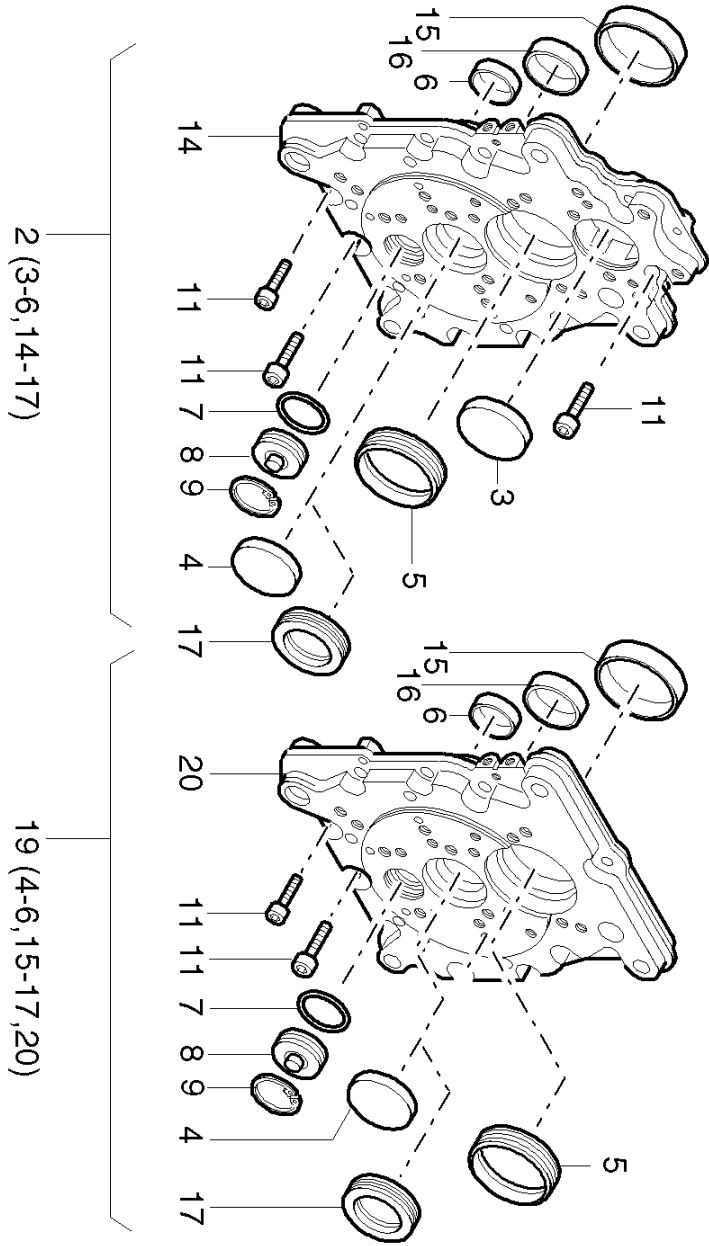
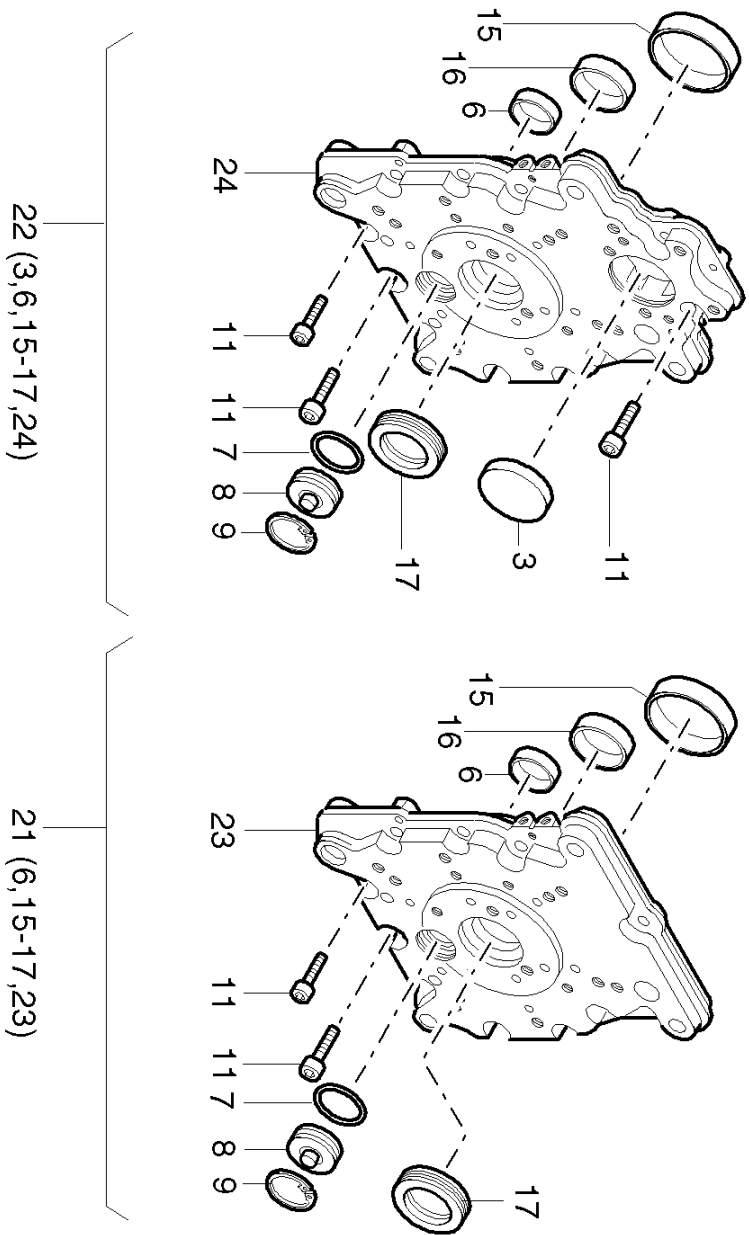

Pos.	Part no.	Description	Qty.	Notice	Add. notice	kg	EA	TA	DA	dDPW	List price
2	01267720	TIMING COVER SAE	1	SAE		2,350	9	12	0		1269,632
3	50325600	COVER 50	1	50		0,023	4	11	1		22,477
4	50325700	COVER 52	1	52		0,021	4	11	1		22,659
5	50325810	OIL SEAL 54X 70X 8	1	54 x 70 x 8 part was replaced by 50325811		0,000	0	11	7	D1	
6	03797600	BEARING BUSH	1			0,009	9	11	0		29,12
7	50330400	O-RING 27X2N	1	27 x 2		0,001	4	11	1	D1	5,4145
8	04000400	COVER	1			0,005	1	11	1		27,30
9	50399000	CIRCLIP 32 X 1,2	1	JL 32 x 1,2 DIN 472		0,003	4	11	1		7,644
11	50417400	ALL.SCREW M 8X30 Z3	13	M 8 x 30 DIN 912-8.8 A3C/6900		0,017	4	11	1		3,367
14	_noorder	No single order	-								
15	04000310	BEARING BUSH	1			0,036	1	11	1		105,9695
16	04023210	BEARING BUSH	1			0,020	1	11	1		58,513
17	50364700	OIL SEAL 32X 52X 7	1	32 x 52 x 7 part was replaced by 50364701		0,000	0	11	7		
19	_nopart	Not in this engine	-								
20	_noorder	No single order	-								
21	_nopart	Not in this engine	-								
22	01281010	TIMING COVER NO.3	1	part run out no successor		2,200	0	12	7		
23	_noorder	No single order	-								
24	_noorder	No single order	-								

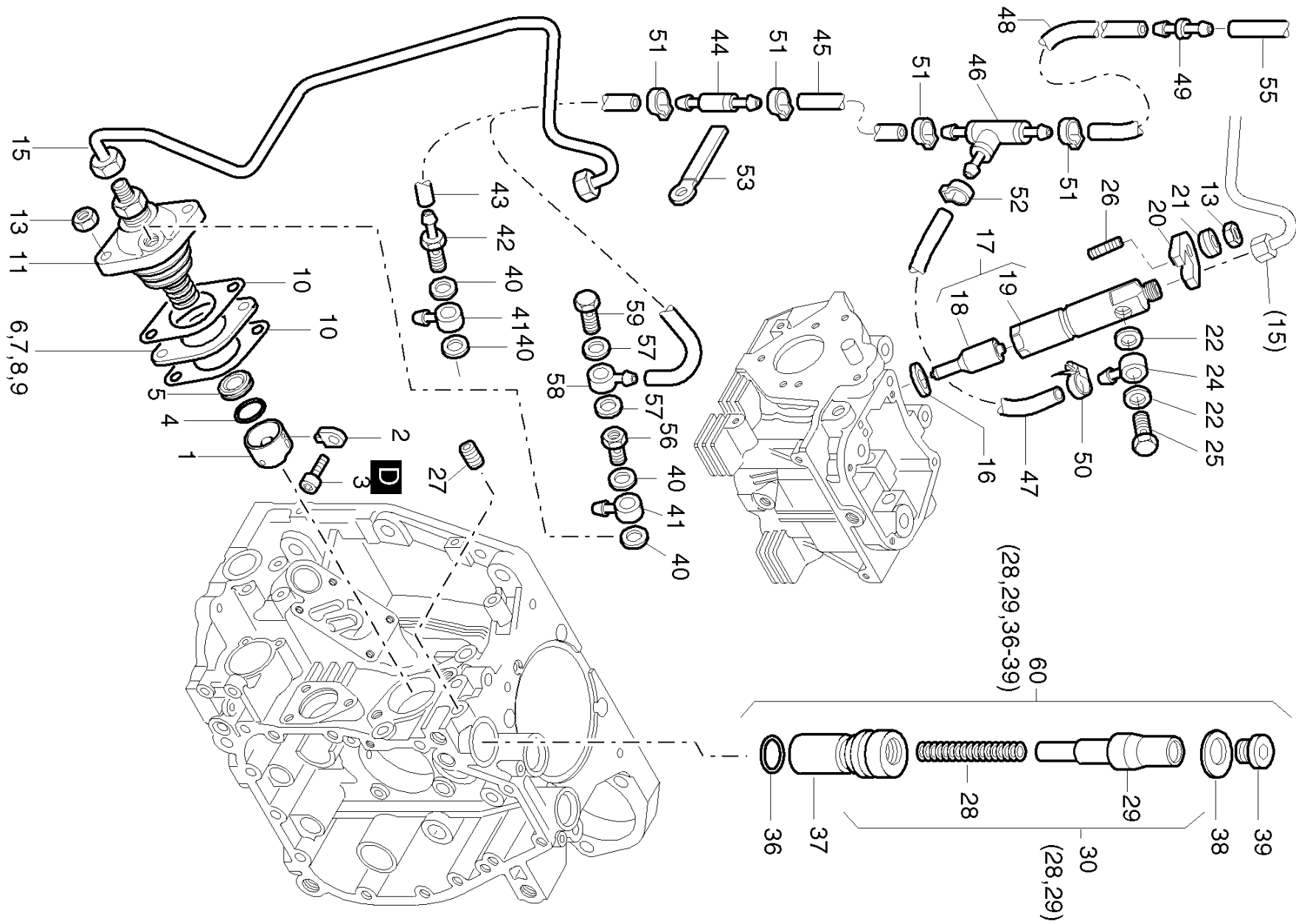

Pos.	Part no.	Description	Qty.	Notice	Add. notice	kg	EA	TA	DA	dDPW	List price
1	50331501	ROLLER TAPPET CPL.	1			0,038	4	11	5		105,6055
2	04000901	GUIDE	1			0,004	1	11	0		19,474
3	50050700	ALL.SCR.M 6X 16	1	M 6 x 16 DIN 912-8.8		0,005	4	11	1		1,729
4	50390200	O-RING 17 X 1,1	0... 1	17 x 1,1		0,001	4	11	1		4,4135
4	50363400	O-RING 17X 1,2	0... 1	17 x 1,2		0,001	4	11	1		5,0505
5	04011700	PLATE	1			0,007	1	11	5		29,12
6	03209700	SHIM 0,3	0... 1	0,30 mm		0,003	1	11	1		6,6885
7	04102400	SHIM 0,60/42,2	0... 1	0,60 mm		0,001	1	11	1		3,8675
8	04102500	SHIM 0,90/42,2	0... 1	0,90 mm		0,009	1	11	1		4,459
9	04102600	SHIM 1,20/42,2	0... 1	1,20 mm		0,013	1	11	1		4,9595
10	04102200	GASKT.INJC.PUMP 0,2	0... 2	0,20 mm		0,001	1	11	1		5,278
10	04102300	GASKT.INJC.PUMP 0,3	0... 2	0,30 mm		0,001	1	11	1		5,6875
10	04071300	GASKET	0... 2	0,10 mm		0,001	1	11	1	D2	2,821
11	05118600	INJECT.PUMP 1Q75/55	1			0,500	4	11	0		1100,645
13	50148000	HEXAGON NUT M 8	3	M 8 DIN 934-8 A3C		0,005	4	11	1		1,4105
15	01245720	FUEL PRESS. PIPE	1			0,145	1	11	0		87,2235
16	40085001	JOINT	1			0,002	4	11	0	d1	10,283
17	50357100	INJECTOR	1			0,253	4	11	0		930,202
18	50362500	NOZZLE DLLA158S1146	1			0,059	4	13	1	P1	298,207
19	_noorder	No single order	-								
20	03792400	FLANGE	1	part was replaced by 03792401		0,000	0	11	0		
21	04035700	WASHER	1			0,007	1	11	1		6,279
22	50000800	JOINT A 6,5X 9,5	2	A 6,5 x 9,5 DIN 7603-Cu		0,001	4	11	1	d2	0,455
24	50333400	BANJO CONNECTION	1			0,005	4	11	1		12,8765
25	50313000	BANJO BOLT M 6	1	M 6		0,005	4	11	1		10,556
26	50038400	STUD M 8X 35	1	M 8 x 35 DIN 835-8.8 A3C		0,017	4	11	1		5,0505
27	50004600	GRUB SCREW M 8X16	1	M 8 x 16 DIN 916-45H A3C		0,003	4	11	1		2,912
28	05035200	PRESSURE SPRING	1			0,005	1	11	1		7,007
29	_noorder	No single order	-								
30	01519500	PIST.+SPRG.EXT.FUEL	1			0,055	1	12	1		87,2235

**\_090.24\_TM12M14 M12 Extra fuel device, Injection equipment 1 D 80.24**

CD-ID: 001M1

Pos.	Part no.	Description	Qty.	Notice	Add. notice	kg	EA	TA	DA	dDPW	List price
36	50328900	O-RING 22X1,6	1	22 x 1,6		0,001	4	11	1	D2	2,3205
37	04001410	CYL.F.EXTR.FUEL DEV	1			0,245	1	11	1		140,686
38	04001600	DISC	1			0,009	1	11	1		4,368
39	50330800	CLOS.SCREW M16X1,5	1	M 16 x 1,5 DIN 908-5.8 A3C Tuf.		0,019	4	11	1		12,376
40	50001100	JOINT A12 X15,5	2	A 12 x 15,5 DIN 7603-Cu		0,001	4	11	1	D2	0,7735
41	50015800	RING PIECE NW6	1	NW 6		0,015	4	11	1		13,3315
42	03662300	HOSE NIPPLE	1			0,034	1	11	5		25,0705
43	04060400	FUEL HOSE 5,0 X 100	1	5 x 2,5 - 100 mm		0,008	1	11	1		5,3235
44	00805500	VENT VALVE	1	part was replaced by 00805501		0,004	0	11	7	P1	
45	03807100	FUEL HOSE 5,0X 150	1	5 x 150 mm		0,010	1	11	1		
45	04060200	FUEL HOSE 5,0 X 55	1	5 x 2,5 - 55 mm		0,005	1	11	5		
46	50157800	HOSE NIPPLE T NW 3	1	NW 3 part was replaced by 05242400		0,009	0	11	7		
46	03989600	HOSE NIPPLE T	1	part was replaced by 03989601		0,000	0	11	7		
47	03902000	FUEL HOSE 3,5X 390	1	3,5 x 390 mm		0,016	1	11	5		
47	03962100	FUEL HOSE 3,5X 160	1	3,5 x 2,5 - 160 mm		0,007	1	11	1		
48	05029600	FUEL HOSE 5,0X 850	1	5 x 850		0,015	1	11	1		
49	50279600	CONNECTING NIPPLE	1			0,006	4	11	1		18,7915
50	50357200	HOSE CLIP 7-11	1	7 - 11 SX5 SW4		0,003	4	11	1		9,373
51	50399801	CLAMP 11,3	4	11,3		0,002	4	11	1		7,3255
52	50399900	CLAMP 9,5	1	9,5		0,001	4	11	5		
53	05001200	CLIP	1			0,005	1	21	1		7,644
55	_noorder	No single order	-								
56	_nopart	Not in this engine	-								
57	_nopart	Not in this engine	-								
58	_nopart	Not in this engine	-								
59	_nopart	Not in this engine	-								
60	01498902	PIST.+CYL.EXTR.FUEL	1			0,328	1	11	1		163,163
D	50223300	LOCTITE 221	1	50 ML		0,077	4	12	0		99,0535



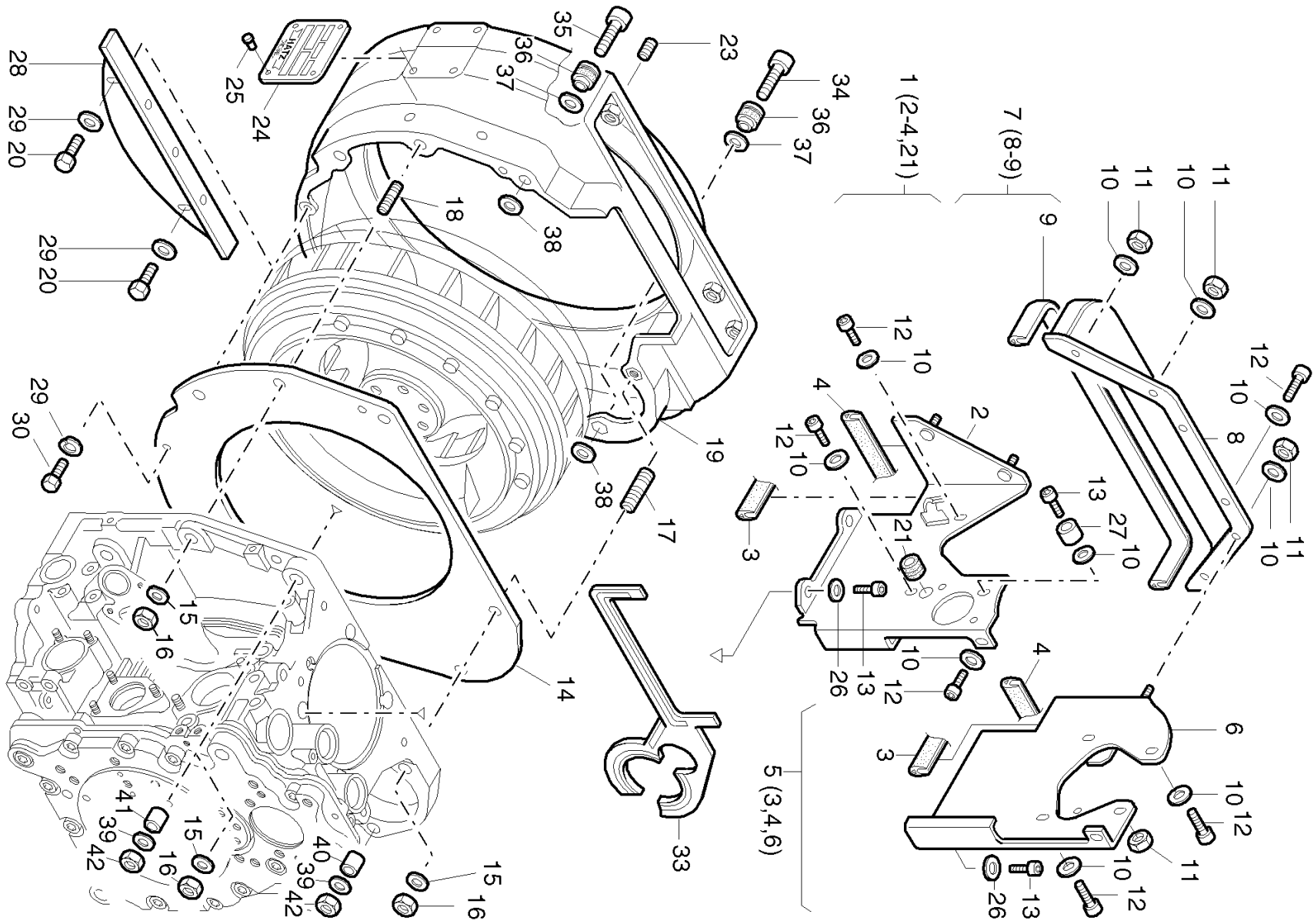

Pos.	Part no.	Description	Qty.	Notice	Add. notice	kg	EA	TA	DA	dDPW	List price
1	01246221	COOLING AIR DUCT.	1	part was replaced by 01246223		0,000	0	11	7		
2	_noorder	No single order	-								
3	04007601	SEALING STRIP32,2MM	2	35 mm		0,002	1	11	1		6,097
4	04007720	SEALING STRIP 76MM	2	76 mm		0,005	1	11	1		7,098
5	01246411	COOLING AIR DUCT.	1	part was replaced by 01246412		0,000	0	11	7		
6	_noorder	No single order	-								
7	01246600	COOLING AIR DUCT	1			0,316	1	11	1		122,8045
8	_noorder	No single order	-								
9	04007901	SEALING STRIP 406MM	1	406 mm		0,029	1	11	1		29,3475
10	50081200	SPRING WASHER A 6	15	A 6 DIN 137 - A3C		0,001	4	11	1		0,455
11	50144400	HEXAGON NUT M 6	4	M 6 DIN 934 - 8 A3C		0,002	4	11	1		1,2285
12	50149100	ALLEN SCREW M 6X 12	12	M 6 x 12 DIN 912-8.8 A3C		0,005	4	11	1		1,092
13	50206300	ALL.SCR.M 8X 18	4	M 8 x 18 DIN 912-8.8 A3C		0,013	4	11	2		2,457
14	04008500	PARTING SHEET	1			0,470	1	11	1		95,7775
15	50093700	FLAT WASHER A 13	6	13 DIN 125-St A3C		0,006	4	11	1		1,729
16	50093600	HEXAGON NUT M 12	6	M12 DIN 934-8 A3C		0,017	4	11	1		2,6845
17	50364900	STUD M12X 40	2	DIN 938-8.8A3C		0,038	9	11	0		5,5055
18	50331400	STUD M12X 35	4	M 12 x 35 DIN 835 - 8.8 A3C part was replaced by 50474900		0,000	0	11	7		
19	04008211	INTERMED.HOUSING	1	SAE 5 part was replaced by 01536500		0,000	0	11	0		
20	50333500	HEXSCREW M 6X 8	2	M 6 x 8 DIN 933-8.8 A3C		0,004	4	11	1		1,5015
21	50334800	RUBBER SLEEVE	1			0,001	4	11	1		3,2305
23	50226000	GRUB SCREW M 8X6	4	M 8 x 6 DIN 913-45H TU.FLEC		0,002	4	11	1		3,9585
24	_nopart	Not in this engine	-								
25	40002500	RIVET 2,4X6	4	2,4		0,001	4	11	1		1,4105
26	_nopart	Not in this engine	-								
27	_nopart	Not in this engine	-								
28	04080410	COVER F.BLOW.DUCTG.	1			0,090	1	11	2		49,14
29	50170900	SPRING WASHER 6	4	6 DIN 128 - A3C		0,001	4	11	1		0,455
30	50177100	HEXSCREW M 6X 16	2	M 6 x 16 DIN 933-8.8 A3C		0,005	4	11	1		1,4105



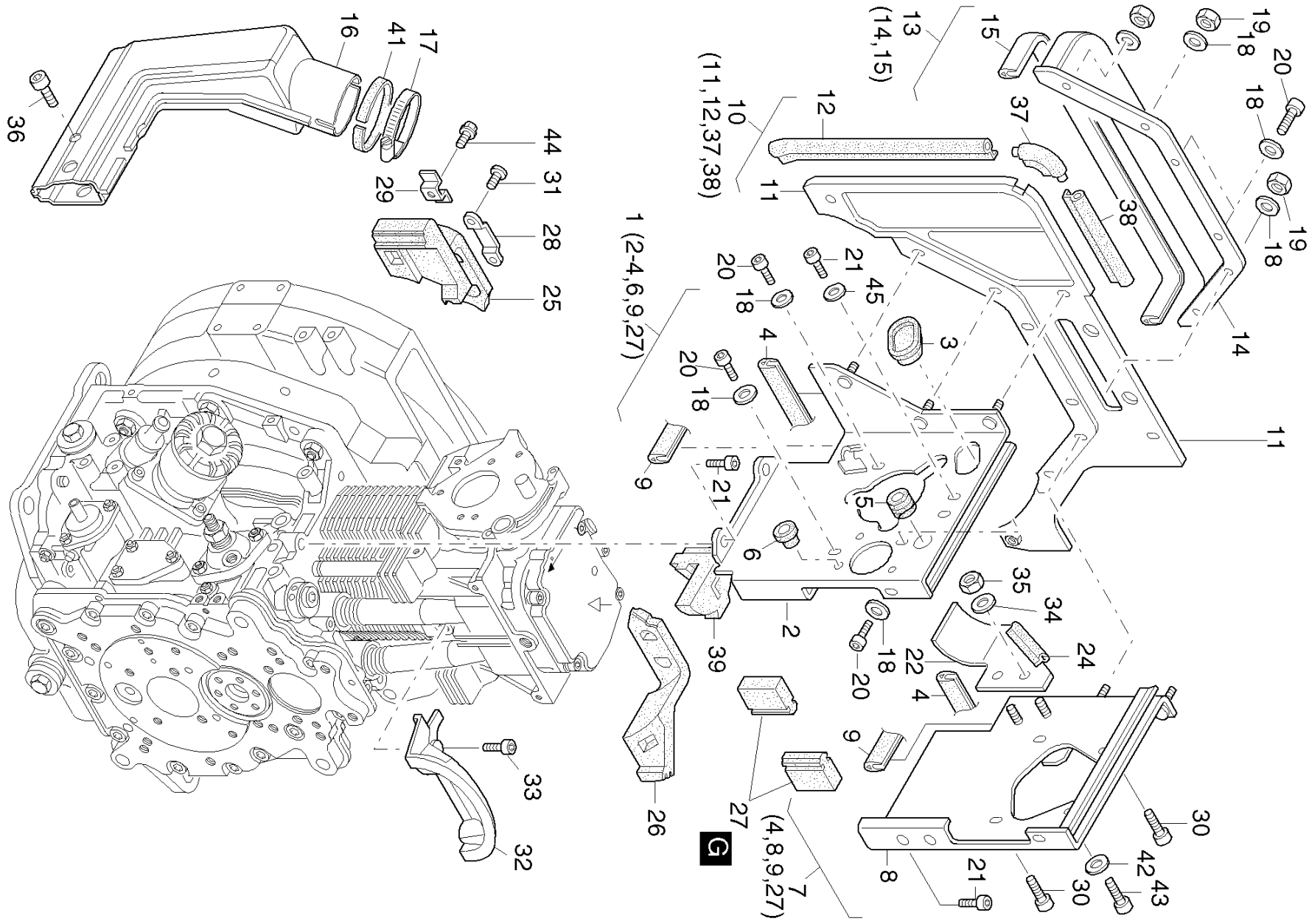

Pos.	Part no.	Description	Qty.	Notice	Add. notice	kg	EA	TA	DA	dDPW	List price
1	01279010	COOLING AIR DUCT.	1	part was replaced by 01279011		0,000	0	11	0		
2	_noorder	No single order	-								
3	04055300	RUBBER SLEEVE	1			0,005	1	11	1		9,828
4	04007720	SEALING STRIP 76MM	2	76 mm		0,005	1	11	1		7,098
5	04055401	JOINT WASHER	1			0,001	1	11	1		5,278
6	50334800	RUBBER SLEEVE	1			0,001	4	11	1		3,2305
7	01278920	COOLING AIR DUCT.	1	part was replaced by 01278921		0,000	0	11	7		
8	_noorder	No single order	-								
9	04007601	SEALING STRIP32,2MM	2	35 mm		0,002	1	11	1		6,097
10	01278710	INTERMEDIATE WALL	1			0,455	1	11	1		252,798
11	_noorder	No single order	-								
12	04066900	SEALG.STRIP 230MM	1	228 mm		0,018	1	11	1		20,4295
13	01277301	COOLING AIR DUCT	1			0,371	1	11	1		194,74
14	_noorder	No single order	-								
15	04007901	SEALING STRIP 406MM	1	406 mm		0,029	1	11	1		29,3475
16	01274502	AIR INTAKE ELBOW	1			0,417	1	11	1		
17	50339900	HOSE CLIP 40-60MM	1	40 / 60		0,031	0	11	1		
18	50144500	FLAT WASHER 6,4	13	6,4 DIN 125-St A3C		0,001	4	11	1		0,455
19	50144400	HEXAGON NUT M 6	4	M 6 DIN 934 - 8 A3C		0,002	4	11	1		1,2285
20	50384200	ALL.SCR.M 6X 12	7	M 6x12 DIN 912-8.8 A3C Tuf. 360 G		0,005	4	11	1		3,2305
21	50206300	ALL.SCR.M 8X 18	5	M 8 x 18 DIN 912-8.8 A3C		0,013	4	11	2		2,457
22	01268010	COOLING AIR DUCT	1			0,075	1	11	1		68,3865
24	04038800	SEALING STRIP 94MM	1	94 mm		0,015	1	11	1		16,198
25	04045010	FILLING PIECE	1			0,071	1	11	1		133,77
26	04044610	FILLING PIECE	1			0,052	1	11	1		103,012
27	04045900	FILLING PIECE	2			0,016	1	11	1		23,9785
28	04090300	SUPPORT	2			0,003	9	11	0		3,185
28	04044900	SUPPORT	2			0,003	1	11	1		3,003
29	04044800	SUPPORT	2			0,002	1	11	1		12,3305
30	50335600	COMBI SCREW M 6X 16	4	M 6 x 16 KZ 1-8.8 A3D		0,005	4	11	1		3,003

Pos.	Part no.	Description	Qty.	Notice	Add. notice	kg	EA	TA	DA	dDPW	List price
31	50335600	COMBI SCREW M 6X 16	4	M 6 x 16 KZ 1-8.8 A3D		0,005	4	11	1		3,003
31	04044700	ALL.SCR. M 8 X 16	4	M 8 x 16		0,009	1	11	1		18,0635
32	01272100	FILLING PIECE	1			0,036	1	11	1		46,137
33	50335600	COMBI SCREW M 6X 16	2	M 6 x 16 KZ 1-8.8 A3D		0,005	4	11	1		3,003
34	50120000	DISC A 6,4	2	A 6,4 DIN 9021-St A3C		0,003	4	11	1		0,455
35	50328300	HEXAGON NUT VM6	2	VM 6 DIN 980-8 A3C		0,002	4	11	1		1,4105
36	50170600	ALL.SCR.M 6X 20	1	M 6 x 20 DIN 912-8.8 A3C		0,007	4	11	1		1,729
37	04066400	GASK.F.INTERME.WALL	1			0,003	1	11	1		15,288
38	04066700	SEALG.STRIP 104MM	1	104 mm		0,011	1	11	1		11,6025
39	_nopart	Not in this engine	-								
41	04089200	SEALG.STRIP13X1X167	1	13 x 1 x 167		0,001	1	11	1		6,097
42	_nopart	Not in this engine	-								
43	_nopart	Not in this engine	-								
44	50289200	HEXSCREW M 6X 12	2	M 6 x 12 KZ 1-8.8 A3D		0,005	4	11	1		1,8655
45	50148100	FLAT WASHER 8,4	1	8,4 DIN 125-St A3C		0,002	4	11	1		0,455
G	50256501	LOCTITE IS 407	1	20 ML		0,033	4	12	0		52,143

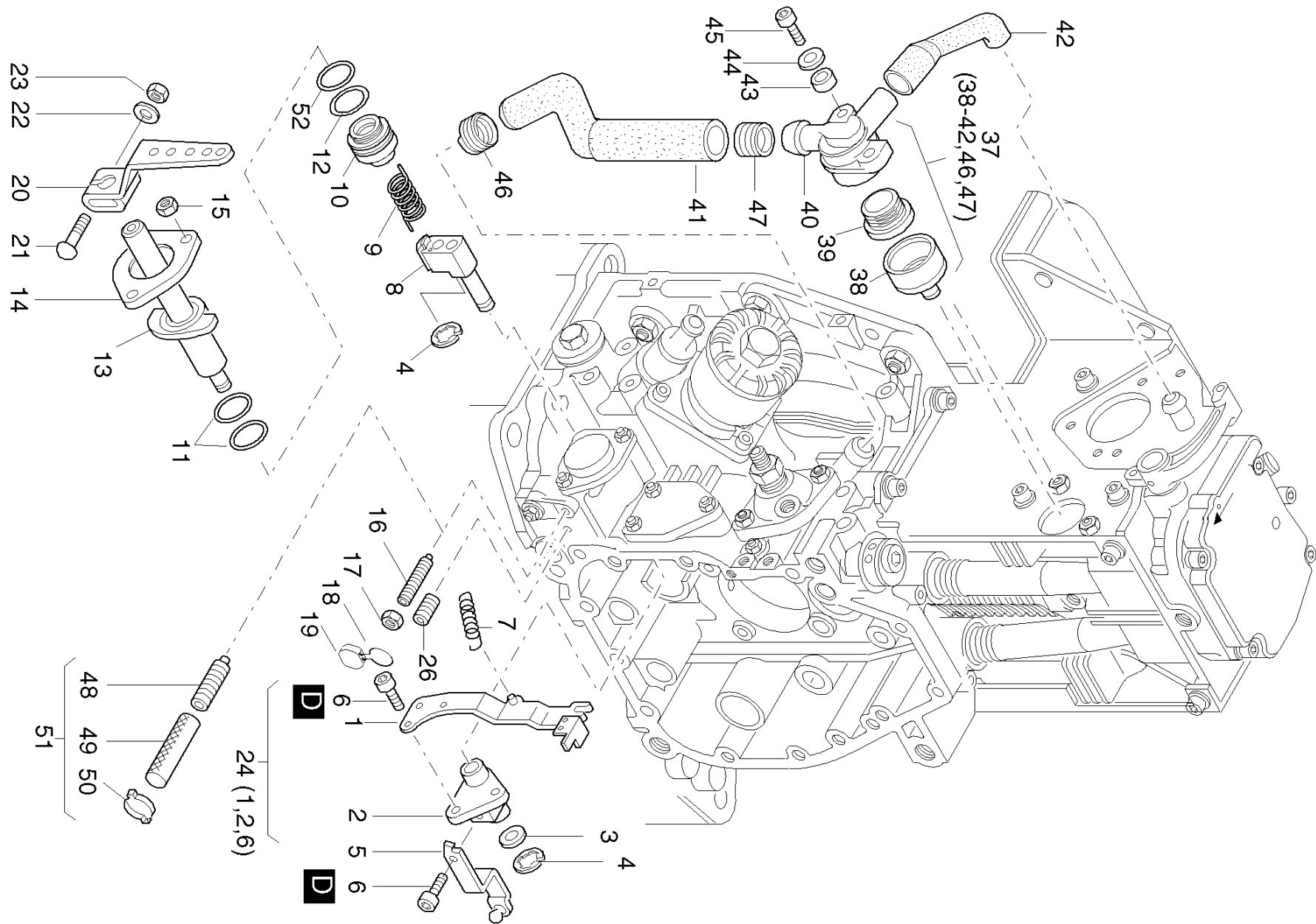

Pos.	Part no.	Description	Qty.	Notice	Add. notice	kg	EA	TA	DA	dDPW	List price
1	_noorder	No single order	-								
2	_noorder	No single order	-								
3	04000100	SHIM	1			0,001	1	11	1		3,003
4	50266100	CIRCLIP 6	2	6 DIN 6799		0,001	4	11	1		0,455
5	04037500	LEVER	1			0,025	1	11	1		16,107
6	50328701	ALL.SCR. M5X8	4	M 5 x 8 DIN 912-8.8 Tuf.		0,003	4	11	1		1,638
7	04000200	TENSION SPRING	1			0,001	1	11	1		9,828
8	01242810	GUIDE	1	part was replaced by 01242811		0,063	0	11	0		
9	03799010	THIGH SPRING	1			0,012	1	11	1		10,01
10	04052710	SPACER RING	1			0,155	1	11	1		39,858
11	50412900	O-RING 18 X 2	2	18 x 2		0,001	4	11	1		1,8655
12	50129900	O-RING 32X37X2,5	1	32 x 2,5		0,001	4	11	1	D1	5,4145
13	01302921	STOP RNG.SPD.CONT.C	1			0,230	1	11	1		134,9075
13	01279221	STOP RNG.SPD.CONT.S	1			0,215	1	11	1		134,9075
14	03799210	FRICTION PLATE	1			0,017	1	11	1		15,288
15	50328300	HEXAGON NUT VM6	3	VM 6 DIN 980-8 A3C		0,002	4	11	1		1,4105
16	03799400	GRUB SCREW	2	M 6 x 45 part was replaced by 50507800		0,005	0	11	7		
17	50144400	HEXAGON NUT M 6	2	M 6 DIN 934 - 8 A3C		0,002	4	11	1		1,2285
18	40021500	SEAL WIRE 0,5-0,3	2	0,5 / 0,3 x 200		0,001	4	11	1		0,455
19	40021400	LEAD SEAL 8 MM	2	8 mm ø		0,001	4	11	1		0,455
20	03888300	HANDLEVER	1			0,100	1	11	1		28,7105
21	03927300	SCREW M 6X 32	1	M 6 x 32		0,012	1	11	1		
22	50144500	FLAT WASHER 6,4	1	6,4 DIN 125-St A3C		0,001	4	11	1		0,455
23	50144400	HEXAGON NUT M 6	1	M 6 DIN 934 - 8 A3C		0,002	4	11	1		1,2285
24	01246803	GOVERNOR LEVER	1			0,110	1	11	1		216,3525
26	50403500	GRUB SCREW M8X20	1	M 8 x 20 DIN 914-45H		0,006	4	11	1		4,8685
37	01317000	BREATHER VALVE	1			0,082	1	11	1		97,552
38	04080300	BREATHER CUP	1			0,004	1	11	1		7,007
39	03568700	DIAPHRAGM	1			0,004	1	11	5		



Pos.	Part no.	Description	Qty.	Notice	Add. notice	kg	EA	TA	DA	dDPW	List price
40	_noorder	No single order	-								
41	04074700	BREATHER HOSE	1	FORM 1694		0,045	1	11	1		20,7935
42	04074800	BREATHER HOSE	1	FORM 1695		0,012	1	11	1		13,5135
43	04080500	BUSH	2	7 x 8 x 8		0,001	1	11	1		6,734
44	50081200	SPRING WASHER A 6	2	A 6 DIN 137 - A3C		0,001	4	11	1		0,455
45	50170700	ALL.SCR.M 6 X 16	2	M 6 x 16 DIN 912-8.8 A3C		0,006	4	11	1		1,729
46	04090500	CLAMP 18MM	1			0,001	1	11	1		2,002
47	_nopart	Not in this engine	-								
48	50405301	GRUB SCREW M6 X 45	1	M 6 x 45 DIN 915 Tuf.		0,005	4	11	1		5,915
49	05038000	HOSE 7 X 12 X 120	1	7 x 12 x 120		0,010	1	21	4		9,828
50	50388300	CLAMP 11-13	1	11 - 13		0,003	4	21	1		8,0535
51	01475600	ADJUST.SCREW1D60/80	1			0,018	1	22	0		21,385
52	50453600	SUPPORTING DISC SS	1	32 x 45 x 2,5 A3C DIN 988		0,015	4	11	1		7,553
D	50223300	LOCTITE 221	1	50 ML		0,077	4	12	0		99,0535

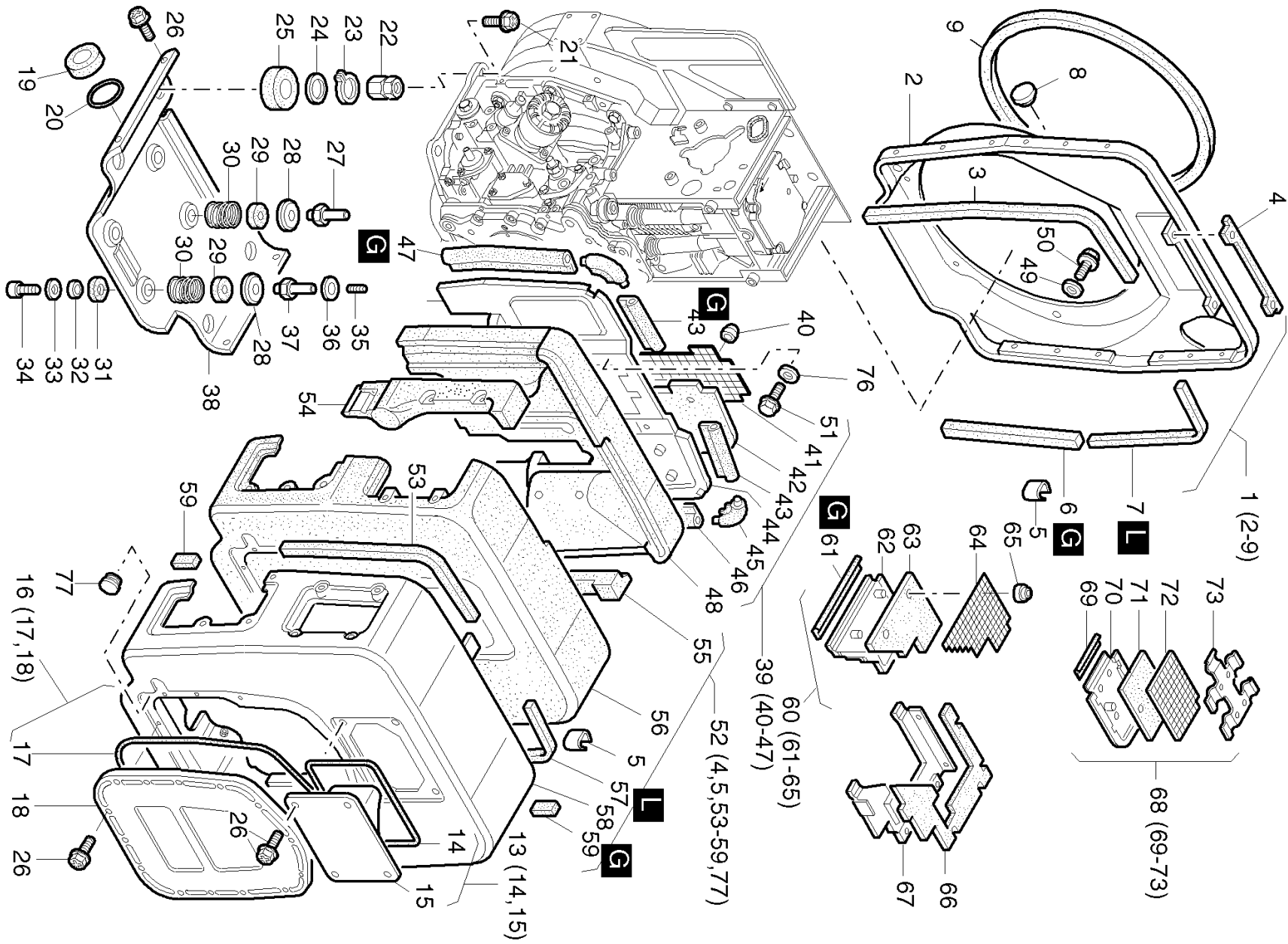

Pos.	Part no.	Description	Qty.	Notice	Add. notice	kg	EA	TA	DA	dDPW	List price
1	01276310	END PLATE	1			2,780	1	11	1		925,197
2	_noorder	No single order	-								
3	04086100	SEALG.STRIP 8X8X640	1	640 mm		0,020	1	11	1		14,1505
4	04073800	GASKET	2			0,006	1	11	1		47,2745
5	04084100	CATCH	8			0,003	1	11	1		5,2325
6	04086000	SEALING STRIP	1	160 mm		0,007	1	11	1		7,189
7	04073500	SEALG.STRIP 8X8X410	1	420 mm		0,017	1	11	1		14,6055
8	50395500	COVER 17,6	1	PHT 17, 6/20		0,001	4	11	1		7,3255
9	04049500	SEALING STRIP	1	1230 mm		0,130	1	11	1		76,8495
13	01276600	COVER SMALL	1			0,215	1	11	1		154,2905
14	04049100	SEALING STRIP	1			0,003	1	11	1		11,7845
15	_noorder	No single order	-								
16	01464200	COVER	1	Handstart, demarr. man.		0,702	1	21	4		195,9685
16	01276700	COVER BIG	1			0,741	1	11	1		185,913
17	04049000	SEALING STRIP	1			0,004	1	11	1		15,015
18	_noorder	No single order	-								
19	03579500	SEALING RING	1	46/22		0,020	9	11	1		29,7115
20	03592301	WASHER 26,1X38X1	1	26,1 x 38 x 1		0,005	1	11	1		7,553
21	50386600	HEXSCREW M10X 20	4	M 10 x 20 A3C W 158.12 - 10.9		0,025	4	21	1		6,643
22	03993700	NUT M10 X 27,5	4	M 10 x 27,5		0,075	1	21	2		17,29
23	50020400	CIRCLIP 24X1,2	4	A 24 x 1,2 DIN 471		0,002	4	11	1		2,002
24	03592301	WASHER 26,1X38X1	4	26,1 x 38 x 1		0,005	1	11	1		7,553
25	03755300	GASKET	4	46/16		0,004	1	11	1		7,553
26	50289200	HEXSCREW M 6X 12	26	M 6 x 12 KZ 1-8.8 A3D		0,005	4	11	1		1,8655
27	04047510	SPACER	2			0,032	1	11	1		17,199
28	04042100	CUP	4			0,010	1	11	1		6,7795
29	04041900	SEALING RING	4			0,002	1	11	1		9,4185
30	04042200	PRESSURE SPRING	4			0,015	1	11	1		9,4185
31	04041800	RUBBER SEAL RING	4			0,004	1	11	1		8,1445
32	04041700	BUSH 7X12X11	4	7 x 12 x 11		0,003	1	11	1		7,7805

Pos.	Part no.	Description	Qty.	Notice	Add. notice	kg	EA	TA	DA	dDPW	List price
33	04042000	WASHER 6,5X22,5X1	4	6,5 x 22,5 x 1		0,003	1	11	1		2,912
34	50170600	ALL.SCR.M 6X 20	4	M 6 x 20 DIN 912-8.8 A3C		0,007	4	11	1		1,729
35	50139200	STUD M 6X 16	4	M 6 x 16 DIN 939-8.8		0,002	4	11	0		1,4105
35	50144500	FLAT WASHER 6,4	4	6,4 DIN 125-St A3C		0,001	4	11	1		0,455
36	50144500	FLAT WASHER 6,4	4	6,4 DIN 125-St A3C		0,001	4	11	1		0,455
37	04041610	SPACER	2			0,029	1	11	1		15,925
38	01270510	BASE PAN	1			1,332	1	11	1		235,508
39	01274810	INTERMEDIATE WALL	1	part was replaced by 01274820		2,015	9	11	0		403,312
40	50388500	HOLDING DISC 4,5	4	4,5		0,002	4	11	1		1,5015
41	04066600	GRID	1			0,075	1	11	1		30,03
42	04046710	INSULATION BORD	1			0,064	1	11	1		38,9025
43	04066700	SEALG.STRIP 104MM	2	104 mm		0,011	1	11	1		11,6025
44	_noorder	No single order	-								
45	04066400	GASK.F.INTERME.WALL	2			0,003	1	11	1		15,288
46	04066900	SEALG.STRIP 230MM	1	228 mm		0,018	1	11	1		20,4295
47	04067000	SEALG.STRIP 280MM	1	280 mm		0,028	1	11	1		23,3415
48	01279410	LINING	1	part was replaced by 01279420		0,000	0	11	7		
49	50144500	FLAT WASHER 6,4	6	6,4 DIN 125-St A3C		0,001	4	11	1		0,455
50	50274800	HEXSCREW M 6X6	6	M 6 x 6 DIN 933-8.8 A3C		0,003	4	11	1		3,003
51	50050700	ALL.SCR.M 6X 16	2	M 6 x 16 DIN 912-8.8		0,005	4	11	1		1,729
52	01276510	BLOWER DUCTING	1			5,500	1	11	0		2144,961
53	04085800	SEALING STRIP	1	8 x 8 x 410 mm		0,014	1	11	1		10,1465
54	04047210	LINING	1			0,065	1	11	1		155,6555
55	04044210	LINING	1			0,025	1	11	0		118,482
56	01272610	LINING	1			1,290	1	11	1		513,877
57	04073500	SEALG.STRIP 8X8X410	1	420 mm		0,017	1	11	1		14,6055
58	_nopart	Not in this engine	-								
59	04085900	SEALING STRIP	1	40 mm		0,001	1	11	1		1,9565
60	01275011	PARITITION WALL	1			0,258	1	11	1		187,278
61	04049400	SEALING STRIP	1	186 mm		0,015	1	11	1		18,382



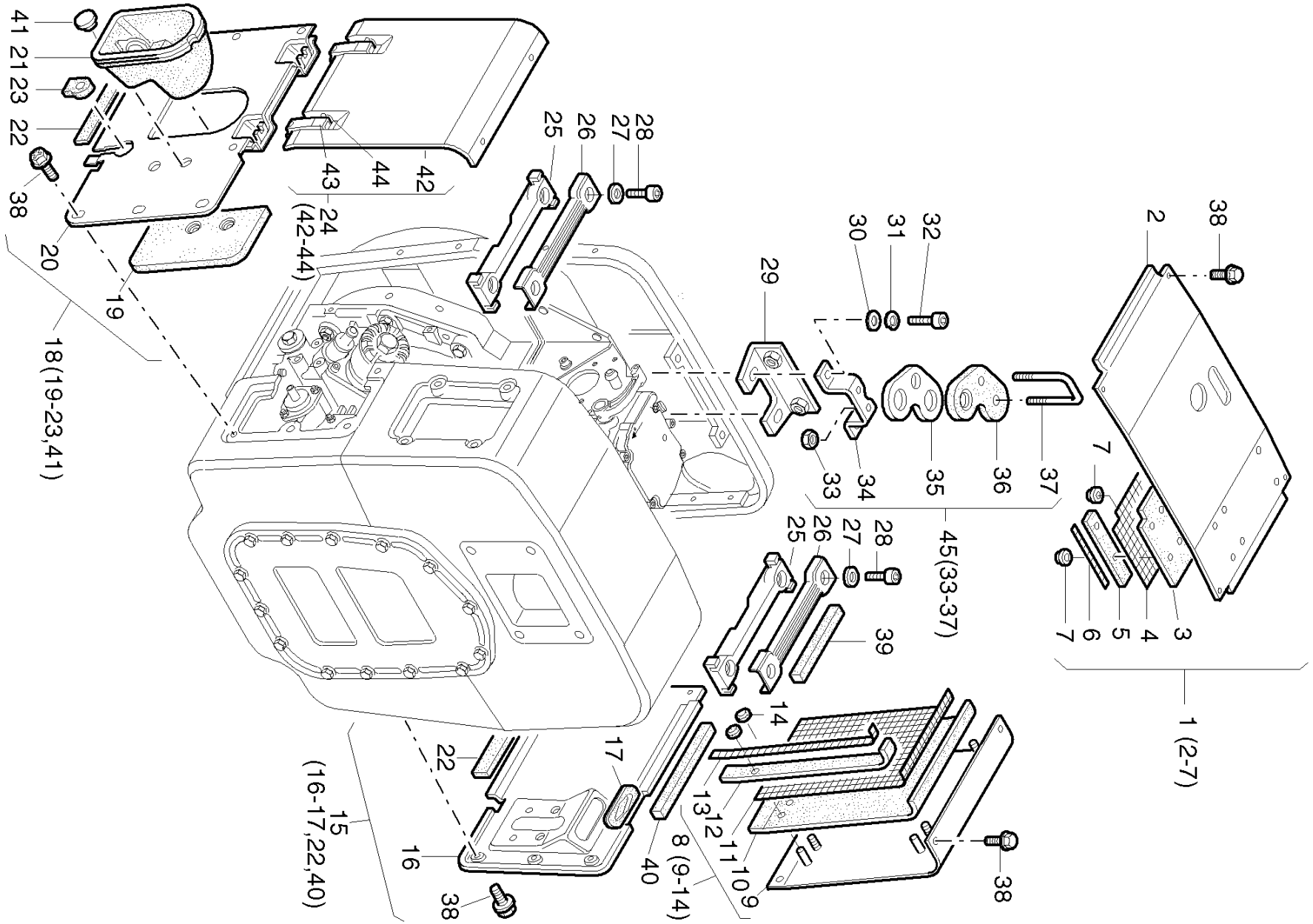

Pos.	Part no.	Description	Qty.	Notice	Add. notice	kg	EA	TA	DA	dDPW	List price
1	01274910	HOOD	1			1,185	1	11	1		249,886
2	_noorder	No single order	-								
3	04046810	INSULATION BORD	1			0,044	1	11	1		33,579
4	04067600	FASTENING GRID	1			0,045	1	11	1		22,841
4	04076300	FASTENING PLATE	1			0,042	0	11	1		
5	04067700	INSULATING BORD	1			0,005	1	11	1		27,937
6	04066000	FIXING RAIL	1			0,004	1	11	1		12,2395
7	50388500	HOLDING DISC 4,5	6	4,5		0,002	4	11	1		1,5015
8	01274710	COWLING	1			1,055	1	11	1		268,905
9	_noorder	No single order	-								
10	04046610	INSULATION PLATE	1			0,105	1	11	1		47,957
11	04067100	FASTENING GRID	1			0,103	1	11	1		33,761
12	04065900	INSULATION BORD	1			0,011	1	11	1		28,1645
13	04076900	FIXING RAIL	1			0,007	1	11	1		15,288
13	04065800	RETAINING STRIP	1			0,010	1	11	1		9,828
14	50388500	HOLDING DISC 4,5	6	4,5		0,002	4	11	1		1,5015
15	01277010	COWLING	1			0,965	1	11	1		237,692
16	_noorder	No single order	-								
17	03993100	RUBBER SLEEVE	1			0,014	1	11	1		9,6005
18	01276910	COWLING	1			0,865	1	11	1		510,328
19	04074000	INSULATING BORD	1			0,034	1	11	1		88,088
20	_noorder	No single order	-								
21	04047010	RUBBER INSERT	1			0,087	1	11	1		156,2925
22	04049700	SEALG.STRIP13X1X195	2	13 x 1 x 195 mm		0,001	1	11	1		8,1445
23	04084600	SEALG.PLATE	1			0,010	1	11	1		9,828
24	01271010	COWLING	1			0,866	1	11	1		330,967
24	04053510	COWLING	1	Dekompr.-Automatik autom. Decompr.		0,845	1	21	4		
25	04067900	RUBBER STRIP	2			0,081	1	11	1		63,154
26	01300400	STIFFNER	2			0,095	1	11	1		67,2945
27	50081200	SPRING WASHER A 6	4	A 6 DIN 137 - A3C		0,001	4	11	1		0,455





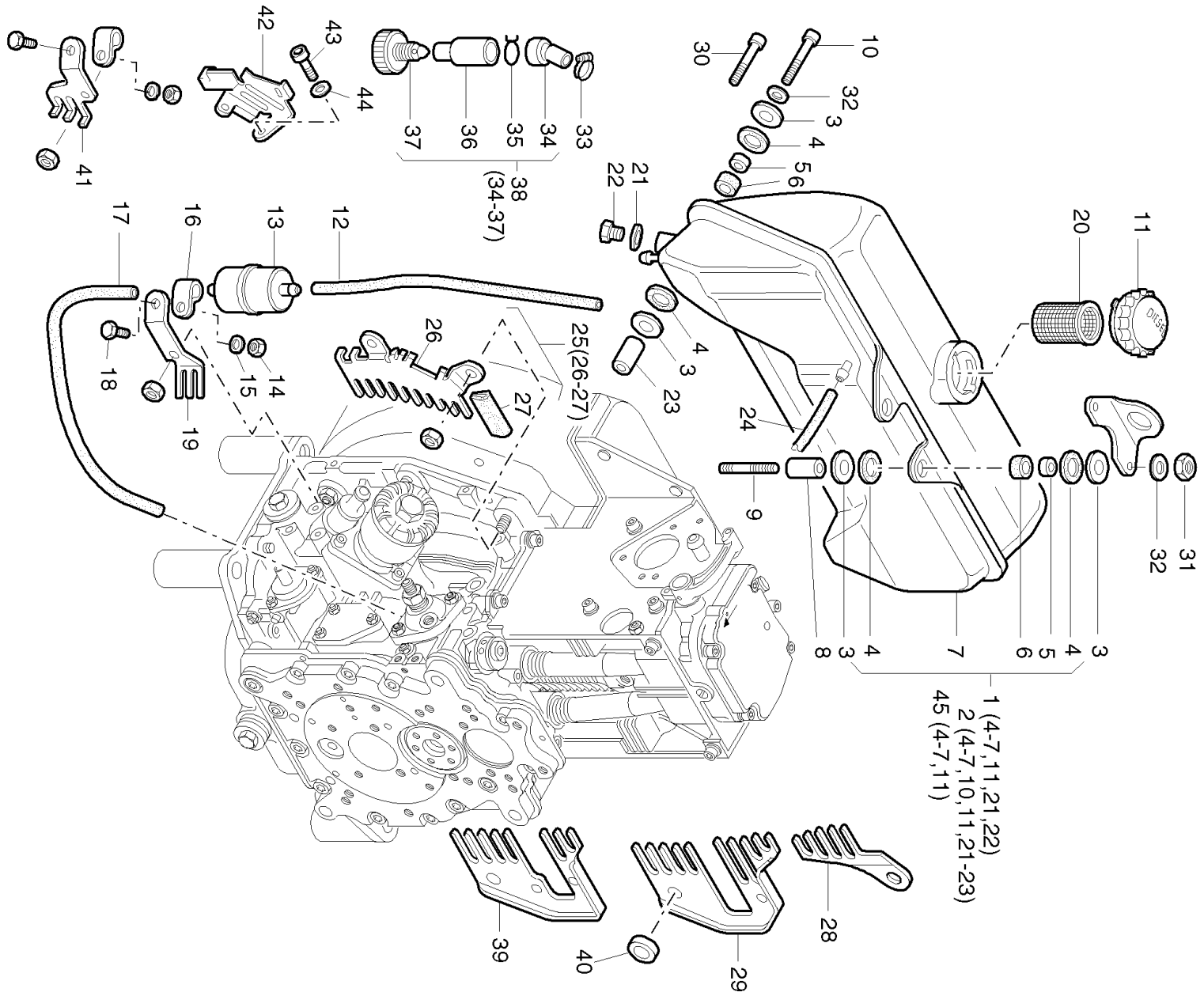

Pos.	Part no.	Description	Qty.	Notice	Add. notice	kg	EA	TA	DA	dDPW	List price
1	_nopart	Not in this engine	-								
2	01494200	FUEL TANK 7 LTRS.	1	7 l		4,000	1	22	1		755,209
3	05097600	WASHER	12	8,5 - 27		0,007	1	11	1		2,912
4	03981802	RUBBER WASHER	12	17 - 25		0,001	1	21	1		8,6905
5	03981701	BUSH 8,4X13X7,5	6	8,4 x 13 x 7,5		0,005	1	21	1		5,096
6	03981900	RUBBER SHELL	6			0,001	1	21	1		1,911
7	_noorder	No single order	-								
8	03989800	BUSH 8,5X20X49	2	8,5 x 20 x 49		0,099	1	21	1		13,013
9	50377001	STUD M 8X 75	2	M 8 x 75 DIN 835-10.9 A3C		0,033	4	21	1		8,9635
10	50177500	ALL.SCR.M 8X 40	4	M 8 x 40 DIN 912-8.8 A3C		0,021	4	11	1		3,1395
11	50385801	CAP FUEL TANK B60	1	DT 60 f.Tank 7l + 10l		0,101	4	21	1	P1	42,3605
12	03801200	FUEL HOSE 7 X 220	1	7 x 220		0,018	1	21	5		
13	40089401	FUEL FILT.(-6C/21F)	1	(10MY) part was replaced by 50478800		0,055	4	21	2	W2	30,303
14	50144400	HEXAGON NUT M 6	1	M 6 DIN 934 - 8 A3C		0,002	4	11	1		1,2285
15	50144500	FLAT WASHER 6,4	1	6,4 DIN 125-St A3C		0,001	4	11	1		0,455
16	03165500	PIPE CLIP	1			0,005	1	11	1		5,46
17	03493600	FUEL HOSE 7 X 330	1	7 x 330 mm		0,030	1	21	2		
18	50165500	HEXSCREW M 6X 12	1	M 6 x 12 DIN 933-8.8 A3C		0,004	4	11	1		1,5015
19	05031900	GUARD	1			0,050	1	11	1		14,924
20	50387300	SIEVE	1	f. Tank 7l + 10l		0,010	4	21	1		42,4515
21	50001000	JOINT A10 X16	1	A 10 x 16 DIN 7603-Cu		0,008	4	11	1		0,5915
22	05126000	DRAIN PLUG	1	M 10 x 12		0,018	1	21	1		27,664
23	05029200	BUSH 9 X 18 X 8	4	9 x18 x 8		0,012	1	21	1		5,8695
24	03663700	FUEL HOSE 5,0 X 50	1	5 x 50 mm		0,005	1	11	5		
25	01490300	PROTEC.GUARD TOP	1			0,087	1	12	1		28,847
26	_noorder	No single order	-								
27	04030901	SEALING STRIP 29MM	1	29 mm		0,002	1	11	1		4,4135
28	05069600	GUARD TOP D60...81	1			0,024	1	21	1		21,7945
29	01528900	PROT.GUARD D60..81	1			0,083	1	21	1		31,213

Pos.	Part no.	Description	Qty.	Notice	Add. notice	kg	EA	TA	DA	dDPW	List price
30	50183000	ALL.SCR. M 8X 35	0... 4	M 8 x 35 DIN 912-8.8 A3C		0,018	4	11	1		1,547
31	50148000	HEXAGON NUT M 8	2	M 8 DIN 934-8 A3C		0,005	4	11	1		1,4105
32	50208500	SPRING WASHER 8	6	8 DIN 128 A3C		0,001	4	11	1		1,4105
33	50448000	CLAMP	1			0,008	4	21	2		9,0545
34	05044001	HOSE 20/12 MM	1			0,003	1	21	2		17,017
35	05036900	HOSE CLIP	1			0,003	4	11	1		7,462
36	05043900	WATER SEPARATOR	1	part was replaced by 05043901		0,012	0	21	0		
37	50414800	CLOS. SCREW M 10	1	M 10		0,007	4	21	2		11,83
38	01519401	WATER SEPARATOR	1	part was replaced by 01519402		0,033	0	21	0		
39	_nopart	Not in this engine	-								
40	_nopart	Not in this engine	-								
41	_nopart	Not in this engine	-								
42	_nopart	Not in this engine	-								
43	_nopart	Not in this engine	-								
44	_nopart	Not in this engine	-								
45	01585100	FUEL TANK 10 LTRS	1	10 l		4,600	1	22	1		896,077

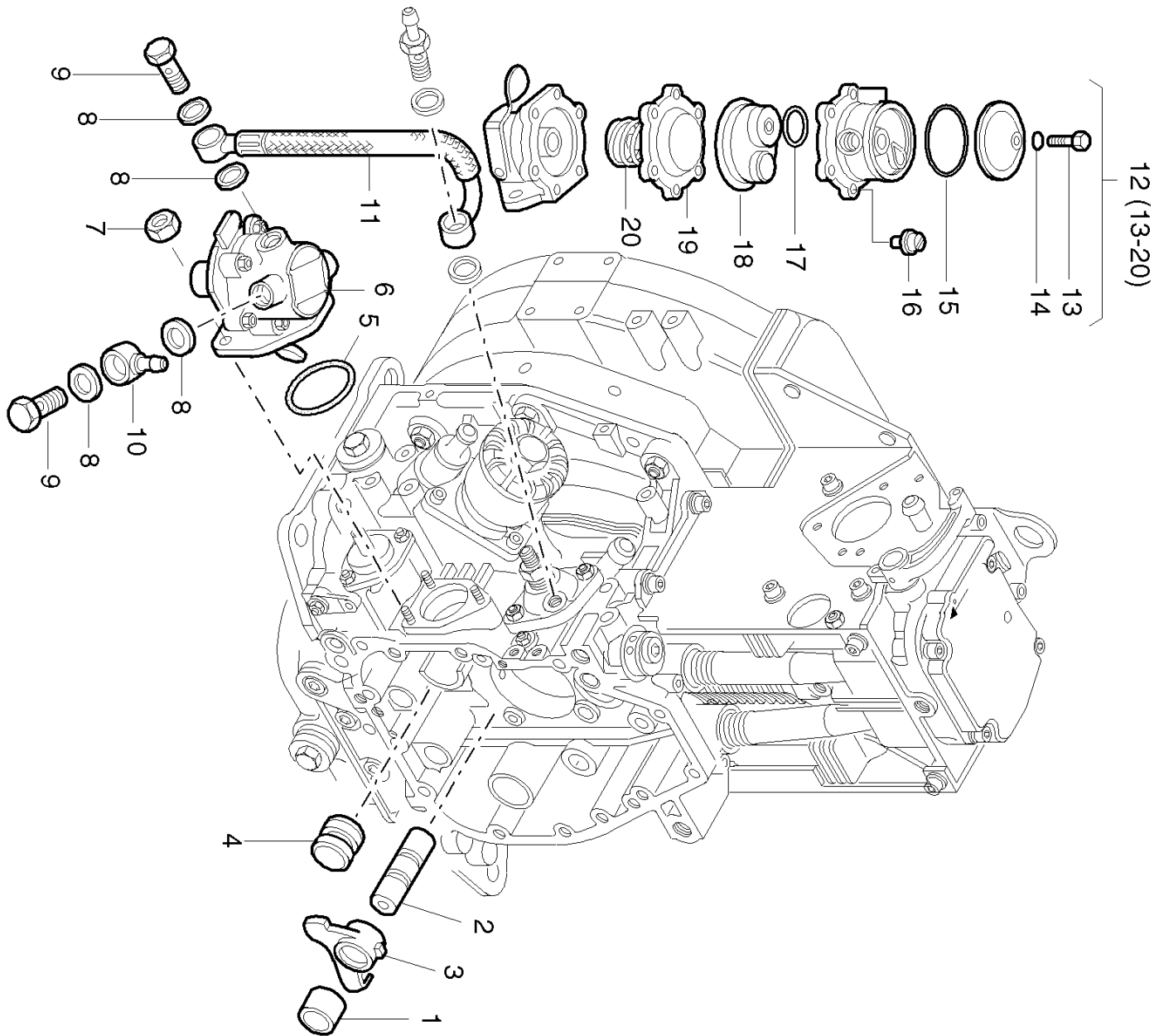

Pos.	Part no.	Description	Qty.	Notice	Add. notice	kg	EA	TA	DA	dDPW	List price
1	04011900	BUSH	1	15x24x17		0,050	1	11	1		12,9675
2	03796401	SHAFT	1			0,072	1	11	1		53,9175
3	04011810	LEVER F.FEED PUMP	1			0,090	1	21	4		170,4885
4	04000800	PLUG	1	ø 22 mm		0,018	1	11	1		13,741
5	50331800	O-RING 35 X 2,8	1	35 x 2,8		0,001	4	21	1		6,0515
6	50332302	FUEL FEED PUMP	1	part was replaced by 05301500		0,284	0	21	1		
7	50328300	HEXAGON NUT VM6	3	VM 6 DIN 980-8 A3C		0,002	4	11	1		1,4105
8	50001200	JOINT A14 X18	4	A 14 x 18 DIN 7603-Cu		0,001	4	11	1		1,001
9	50006400	BANJO BOLT 10-3	2	10-3 DIN 7643		0,029	4	11	1		8,6905
10	50015900	RING PIECE NW8	1	NW 8 / 6		0,025	4	11	1		18,0635
11	01468801	FUEL PIPE	1			0,070	1	21	5		90,4085
12	49062501	VALV.PLAT.W. O-RING	1	Reparatursatz, repair kit		0,075	4	23	0		95,6865
13	_noorder	No single order	-								
14	_noorder	No single order	-								
15	50399500	O-RING 37 X 2,5	1	37 x 2,5		0,001	9	21	0		7,189
16	_noorder	No single order	-								
17	_noorder	No single order	-								
18	_noorder	No single order	-								
19	_noorder	No single order	-								
20	_noorder	No single order	-								

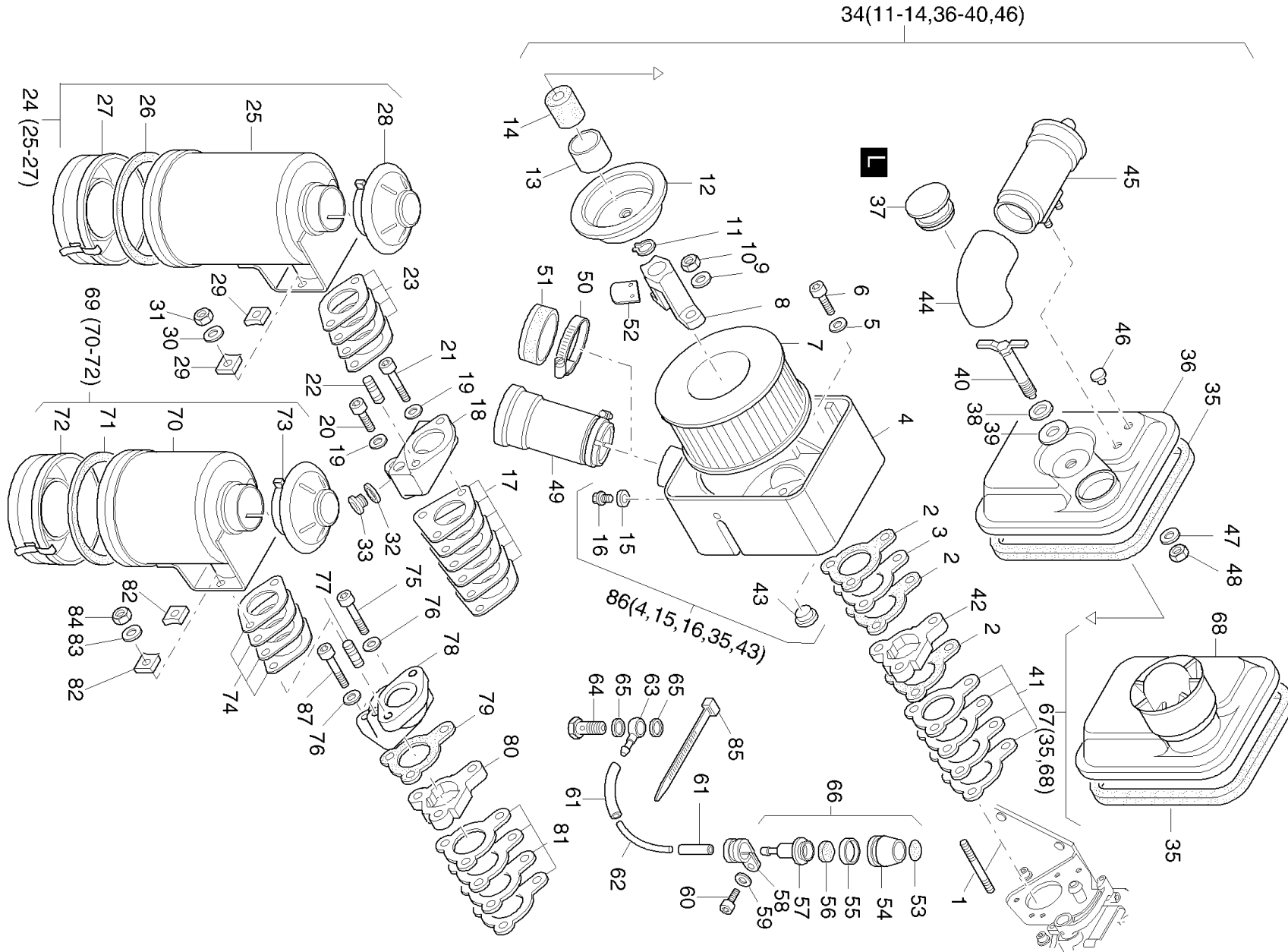

Pos.	Part no.	Description	Qty.	Notice	Add. notice	kg	EA	TA	DA	dDPW	List price
1	50038900	STUD M 8X 60	2	M 8 x 60 DIN 855-8.8		0,025	4	21	1		5,7785
2	04006300	GASKET	2			0,001	1	21	1	d2	2,912
3	04006200	INSULATING FLANGE	1			0,014	1	21	1		13,104
4	_noorder	No single order	-								
5	50095100	SPRING WASHER A 8	1	A 8 DIN 137 A3C		0,001	4	11	1		0,455
6	50398400	ALL.SCR.M8X45A3C	1	M 8 x 45 DIN6912-8.8 A3C		0,023	4	21	1		3,9585
7	01493000	AIRFILTER ELEMENT	1			0,370	4	21	1	W2	79,3065
8	01483400	RETAINING BRACKET	1	part was replaced by 01483401		0,000	0	21	0		
9	50148100	FLAT WASHER 8,4	2	8,4 DIN 125-St A3C		0,002	4	11	1		0,455
10	50129500	HEXAGON NUT M 8	2	M 8 DIN 985-8 A3C		0,002	4	11	1		2,6845
11	50412000	CIRCLIP 10 X 1	1	A 10 x 1 DIN 471		0,001	4	11	1		0,455
12	05036400	CENTERING COVER	1			0,231	1	21	1		48,958
13	05039300	BUSH 33X35X23,5	1	33 x 35 x 23,5		0,019	1	21	1		9,737
14	03579400	SEALING RING	1			0,012	1	11	1		18,746
15	50062400	JOINT A10 X13,5	1	A 10 x 13,5 DIN 7603-Cu		0,001	4	11	1		0,364
16	50062300	CLOS.SCREW M10X1	1	M 10 x 1 DIN 908-5.8 A3C		0,005	4	11	1		4,3225
17	01280201	GASKET OILBATH AIRF	1			0,045	1	21	2		20,5205
18	03987200	INTERMEDIATE FLANGE	1	part was replaced by 05258500		0,600	0	21	0		
19	50095100	SPRING WASHER A 8	3	A 8 DIN 137 A3C		0,001	4	11	1		0,455
20	50175900	ALL.SCR.M 8X 30	1	M 8 x 30 DIN 912-8.8 A3C		0,017	4	11	1		2,6845
21	50288800	ALL.SCR.M 8X 55	2	M 8 x 55 DIN 912-8.8 A3C		0,027	4	11	1		3,6855
22	50145400	STUD M 10X 28	2	M 10 x 28 DIN 835-8.8 A3C		0,024	4	11	1		5,551
23	01158700	GASKET OILBATH AIRF	1			0,026	1	21	2		16,3345
24	01078501	OILBATH AIRFILTER	1			2,000	4	21	2		464,0545
25	_noorder	No single order	-								
26	49038000	PACKING RING	1			0,012	4	23	1		12,376
27	49056600	OIL CONTAINER	1			0,300	4	23	1		94,5035
28	40036700	RAIN PROTECTION CAP	1	ø 62 mm		0,084	4	21	2		51,961
29	03945400	PLATE	2			0,047	1	21	2		12,5125
30	50135600	SPRING WASHER 10	2	10 DIN 128 A3C		0,002	4	21	1		0,455

Pos.	Part no.	Description	Qty.	Notice	Add. notice	kg	EA	TA	DA	dDPW	List price
31	50145800	HEXAGON NUT M 10	2	M 10 DIN 934-8 A3C		0,011	4	11	1		2,002
32	50001600	JOINT A22 X27	1	A 22 x 27 DIN 7603 Cu		0,002	4	11	1		2,2295
33	50140400	DRAIN PLUG M 22X1,5	1	AM22x1,5DIN7604-5.8A3C		0,037	4	11	1		7,462
34	01279510	COVER F. AIRFILTER	1			0,795	1	21	1		249,795
35	04047701	SEALING STR. LG 704	1	705 mm		0,060	1	21	1		39,039
36	_noorder	No single order	-								
37	05039402	CLOSING COVER	1			0,012	1	21	1		8,099
38	03814100	INSULATING DISC	1			0,002	1	21	1		4,368
39	05038700	WASHER 11 X 36 X 3	1	11 x 36 x 3		0,022	1	21	1		5,369
40	01490800	WING SCREW	1			0,074	1	21	1		52,871
41	01287900	GASKET AIRFILTER	1			0,024	1	21	1		17,1535
42	04047300	INTERMEDIATE FLANGE	1			0,075	1	21	1		42,315
43	50395700	COVER 15	1	15 PHT		0,001	9	11	0		7,189
44	05038910	ELBOW F. CYCLON	1			0,087	1	21	2		30,8035
45	01491010	CYCLONE	1			0,258	4	21	2		157,5665
46	50411900	CLOSING PLUG 7	2	F 2 PHT SCHW.		0,001	4	21	1		4,5955
47	50120000	DISC A 6,4	2	A 6,4 DIN 9021-St A3C		0,003	4	11	1		0,455
48	40028300	HEX.NUT M 6	2	VM 6 DIN 980 C3P		0,003	4	11	1		2,1385
49	01411000	CYCLONE	1			0,255	4	21	4		151,697
50	50406600	HOSE CLIP 40/60	1	40 / 60		0,036	4	21	1		9,737
51	00575900	CAP	1			0,064	1	11	1		41,496
52	05033500	VALVE PLATE	1			0,001	1	21	1		2,3205
53	05044501	INDIC. PLATE	1			0,001	1	21	1		10,3285
54	05043601	RUBBER CAP	1			0,002	1	21	1		28,847
55	05045600	SIGNAL RING	1	(grün, green, vert, verde)		0,001	1	21	1		2,002
56	05137200	FILTER	1	Filter, Filtre, Filtro ø 20 mm		0,001	1	21	1		1,001
57	05043700	ADAPTER	1			0,014	1	21	1		40,8135
58	50173500	PIPE CLIP	1	10 / 15		0,010	4	11	1		6,8705
59	50170900	SPRING WASHER 6	1	6 DIN 128 - A3C		0,001	4	11	1		0,455
60	50170600	ALL.SCR.M 6X 20	1	M 6 x 20 DIN 912-8.8 A3C		0,007	4	11	1		1,729



Pos.	Part no.	Description	Qty.	Notice	Add. notice	kg	EA	TA	DA	dDPW	List price
61	03961400	FUEL HOSE 3,5 X 50	2	3,5 x 50		0,002	1	21	0		2,457
62	05043800	HOSE 2 X 4 X 170	1	2 x 4 x 170		0,003	1	21	1		9,828
63	50159500	RING PIECE NW4	1	NW 4 / 3		0,011	4	21	1		12,376
64	50006200	BANJO BOLT 6-3	1	6 - 3 DIN 7643		0,012	4	11	1		8,099
65	50062400	JOINT A10 X13,5	2	A 10 x 13,5 DIN 7603-Cu		0,001	4	11	1		0,364
66	01499801	MAINT.INDICATOR	1			0,026	1	21	1		82,446
67	01705500	COVER F. AIRFILTER	1			0,510	4	22	2		244,2895
68	_noorder	No single order	-								
69	_nopart	Not in this engine	-								
70	_noorder	No single order	-								
71	_noorder	No single order	-								
72	_noorder	No single order	-								
73	_noorder	No single order	-								
74	_noorder	No single order	-								
75	_noorder	No single order	-								
76	_noorder	No single order	-								
77	_noorder	No single order	-								
78	_noorder	No single order	-								
79	_noorder	No single order	-								
80	_noorder	No single order	-								
81	_noorder	No single order	-								
82	_noorder	No single order	-								
83	_noorder	No single order	-								
84	_noorder	No single order	-								
85	50358400	STRAP	1	200 x 4,8 mm SCHWARZ		0,001	4	11	1		0,6825
86	01486600	AIRFILTER HOUSING	1	part was replaced by 01486601		0,000	0	21	7		
87	_noorder	No single order	-								
L	50256600	SILICON SEALER	1			0,130	4	12	0		193,4205

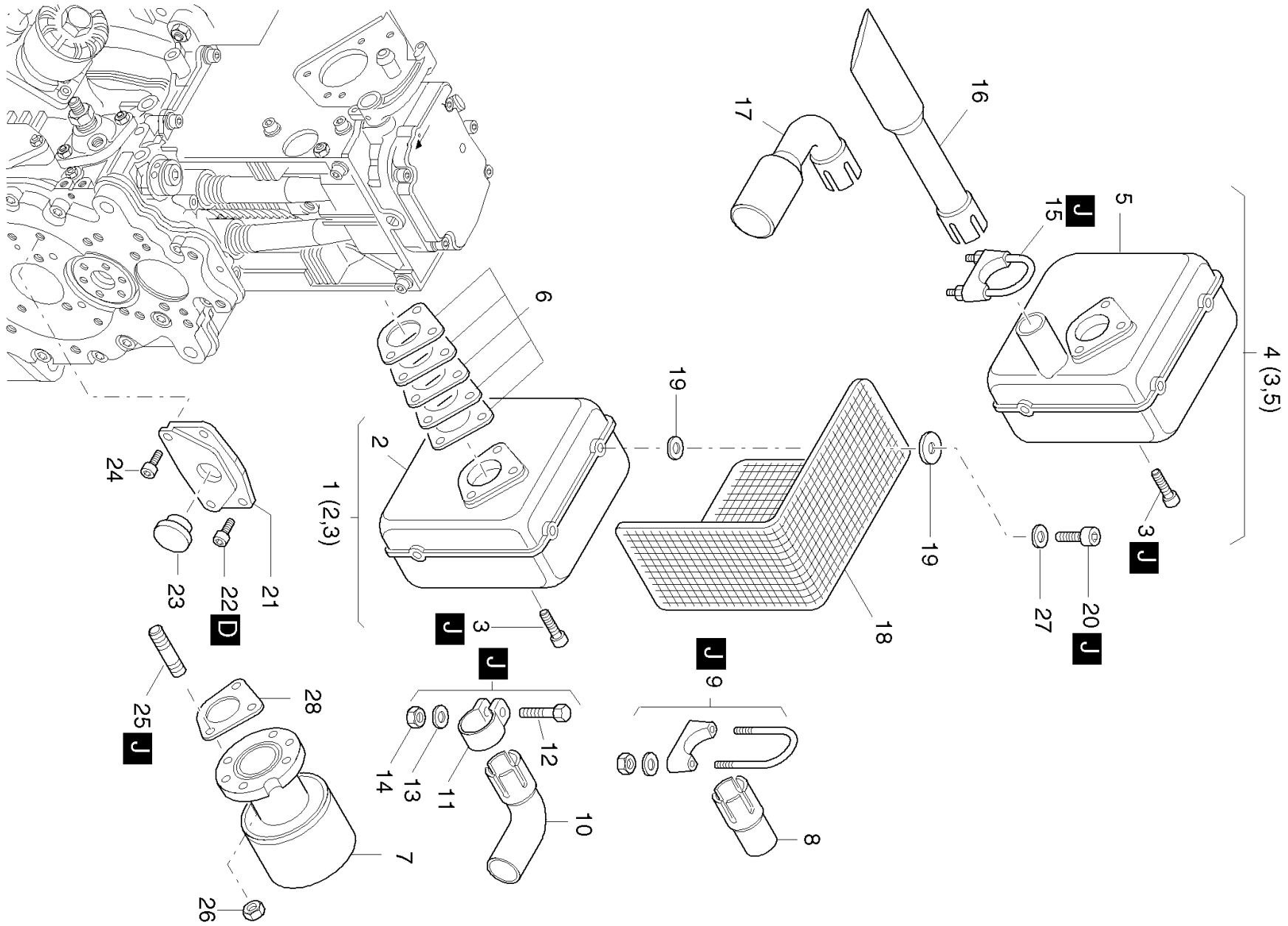

Pos.	Part no.	Description	Qty.	Notice	Add. notice	kg	EA	TA	DA	dDPW	List price
1	01498800	EXHAUST SILENCER S	1			4,690	1	22	1		872,5535
2	_noorder	No single order	-								
3	50404000	ALL.SCR.M 8 X 30	3	M 8 x 30 DIN 912-8.8 C4P		0,017	4	21	1		2,457
4	01507500	EXHAUST SILENCER S	1			4,971	1	22	2		872,5535
5	_noorder	No single order	-								
6	01429100	GASKET EXHAUST SIL.	1			0,045	1	21	1	d1	23,3415
7	01500900	EXHAUST SILENCER	1	part was replaced by 01500901		0,000	0	21	7		
8	_nopart	Not in this engine	-								
9	_nopart	Not in this engine	-								
10	03877300	EXHAUST ELBOW	1			0,264	1	21	2		90,9545
11	03877700	PIPE CLIP 52,5	1	52,5 mm		0,147	1	21	2		23,1595
12	50249500	HEXSCREW M 10X50	1	M 10 x 50 DIN 931-8.8 A3C		0,041	4	21	1		5,0505
13	50145900	FLAT WASHER 10,5	1	B 10,5 DIN 125-St A3C		0,004	4	11	1		1,4105
14	40028600	HEX.NUT M10	1	VM 10 DIN 980-8 C3A		0,010	4	11	1		2,6845
15	50388100	PIPE CLIP 1 3/8-36	1	3/8-36 883-4 ZN		0,104	4	21	2		19,7015
16	03997101	EXHAUST TUBE	1			0,332	1	21	2		135,954
17	03997000	EXHAUST ELBOW	1			0,321	1	21	2		199,199
18	01191902	GUARD	1			0,425	1	21	1		191,009
19	05034200	SPRING WASHER	10	6,5 x 38		0,011	0	21	7		
20	50255700	ALL.SCR.M 6X 12	5	M 6 x12 DIN 912-8.8 C4A		0,005	4	21	1		1,729
21	03985300	GUARD	1			0,056	1	21	2		33,67
22	50135700	ALL.SCR.M10X 16	2	M 10 x 16 DIN 912-8.8 A3C		0,021	4	21	1		3,6855
23	40091400	CLOSING CAP	1	F24 SCHW.		0,004	4	21	2		3,6855
24	50165400	ALL.SCR.M 8X 16	2	M 8 x 16 DIN 912-8.8 A3C		0,009	4	21	1		2,6845
25	50037300	STUD M 8X 18	2	M 8 x 18 DIN 835-10.9		0,011	4	11	1		2,912
26	40028400	HEX.NUT M 8	2	VM 8 DIN 980-8 C3A		0,008	4	11	1		2,2295
27	50120000	DISC A 6,4	5	A 6,4 DIN 9021-St A3C		0,003	4	11	1		0,455
28	03956900	GASKET	2	part was replaced by 01429100		0,010	0	21	1		
D	50223300	LOCTITE 221	1	50 ML		0,077	4	12	0		99,0535
J	50283004	HIGH TEMP.PASTE	1			0,110	4	12	0		71,617

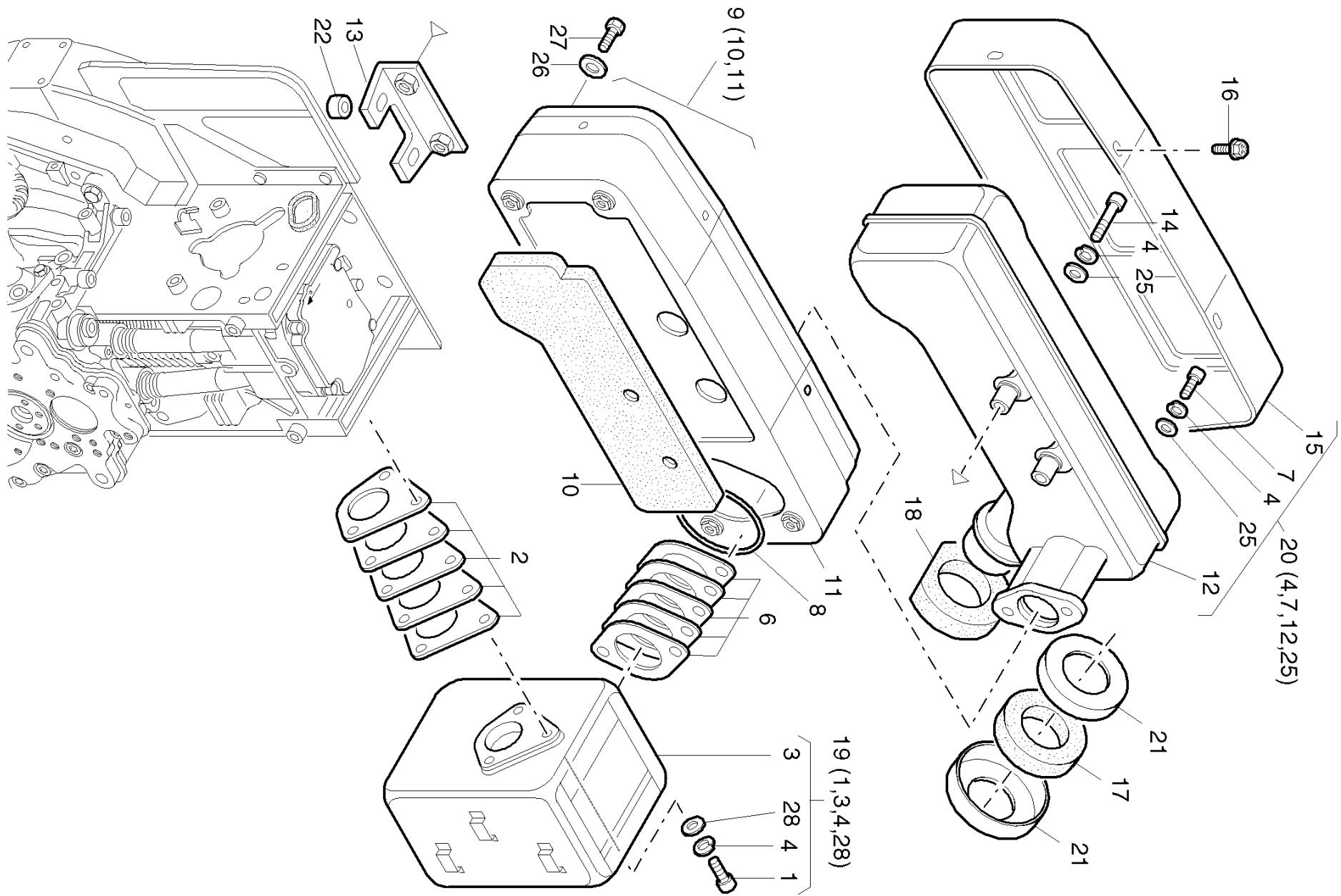

Pos.	Part no.	Description	Qty.	Notice	Add. notice	kg	EA	TA	DA	dDPW	List price
1	50404000	ALL.SCR.M 8 X 30	3	M 8 x 30 DIN 912-8.8 C4P		0,017	4	21	1		2,457
2	01429100	GASKET EXHAUST SIL.	1			0,045	1	21	1		23,3415
3	_noorder	No single order	-								
4	50347301	SPRING WASHER 8	7	VHZ 8 A3C		0,001	4	11	1		0,455
6	01287800	GASKET EXHAUST SIL.	1			0,024	1	21	1		17,5175
7	50403900	ALL.SCR.M 8 X 25	2	M 8 x 25 DIN 912-8.8 C4P		0,015	4	21	1		2,2295
8	50349700	O-RING 100X2,5	1	100 x 2,5		0,002	4	11	1		13,468
9	01278200	EXHAUST CAPS.INSIDE	1			1,385	1	21	1		520,429
10	04045400	INSULATION PLATE	1			0,008	1	21	1		18,0635
11	_noorder	No single order	-								
12	_noorder	No single order	-								
13	01282710	SUPPORT	1			0,253	1	21	1		60,3785
14	50404100	ALL.SCREW M 8 X 60	2	M 8 x 60 DIN 912-8.8 C4P		0,030	4	21	1		3,8675
15	01274001	EXHAUST CAPS.OUTSID	1			1,400	1	21	1		264,264
16	50289200	HEXSCREW M 6X 12	6	M 6 x 12 KZ 1-8.8 A3D		0,005	4	11	1		1,8655
17	04050000	SEALING RING	1			0,001	1	21	1		8,645
18	_nopart	Not in this engine	-								
19	01469010	PRE SILENCER "C"	1			3,317	1	12	1		1350,258
20	01469100	SILENCER "C"	1			3,520	1	12	1		1625,3965
21	_nopart	Not in this engine	-								
22	_nopart	Not in this engine	-								
25	50115700	DISC 8,4	4	8,4 DIN433-St 140 HV		0,002	4	11	1		0,455
26	50002700	SPRING WASHER 6	4	6 DIN 128		0,001	4	11	1		0,455
27	50025700	HEXSCREW M 6X 16	4	M 6 x 16 DIN 933-8.8		0,005	4	11	1		1,4105
28	50115700	DISC 8,4	3	8,4 DIN433-St 140 HV		0,002	4	11	1		0,455

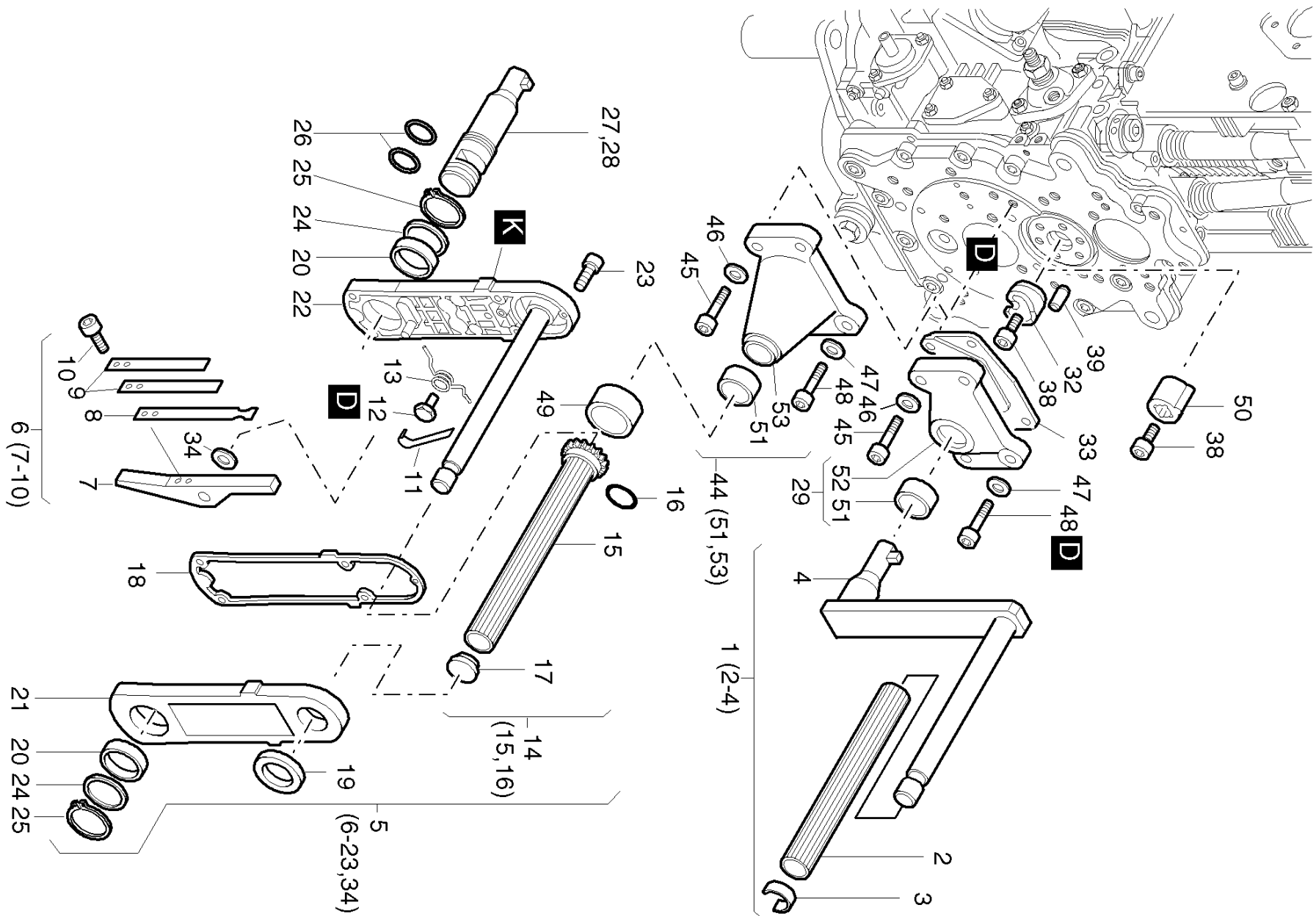

Pos.	Part no.	Description	Qty.	Notice	Add. notice	kg	EA	TA	DA	dDPW	List price
1	01248002	STARTING HANDLE 80	1	80 mm		1,350	1	21	2		304,1675
1	01426502	STARTING HANDLE 140	1	140 mm		1,450	1	21	4		414,1865
1	01426702	STARTING HANDLE 160	1	160 mm		1,500	1	21	4		417,872
1	01433202	STARTING HANDLE 275	1	275 mm		1,870	1	21	4		473,837
1	01469800	STARTING HANDLE 330	1	330 mm		2,370	1	21	0		493,0835
1	01407302	STARTING HANDLE 200	1	200 mm		1,600	1	21	4		455,5005
2	03522400	HANDLE	1			0,050	1	21	2		21,931
3	03515400	SNAP RING	1			0,001	1	21	2		6,1425
4	_noorder	No single order	-								
5	01027805	CR.HANDLE-SAFETY A	1	"A"		1,440	1	21	1		785,1935
6	01011404	LEVER	1			0,125	1	21	1		160,888
7	_noorder	No single order	-								
8	03812102	PLATE SPRING	1			0,007	1	21	1		13,5135
9	03917100	PLATE SPRING	1			0,006	1	21	1		11,648
10	50316500	ALL.SCREW M 5X 8	2	M 5 x 8 DIN 6912-8.8 A3C		0,002	4	11	1		2,912
11	03954900	PLATE SPRING	1			0,005	1	21	1		11,648
12	03955600	HEXSCREW	1			0,003	1	21	1		11,648
13	03955900	SPRING A	1	"A"		0,002	1	21	1		11,648
14	01011310	HANDLE CPL.	1			0,100	1	22	0		202,8845
15	_noorder	No single order	-								
16	50169100	O-RING19 X 1,8	1	19 x 1,8		0,001	4	21	1		1,729
17	50199200	CLOSING PLUG	1	V18 NATUR		0,002	4	21	1		2,3205
18	03813000	GASKET	1			0,001	1	21	1		7,007
19	50194200	OIL SEAL 28X35X4	1	28 x 35 x 4		0,004	4	21	1		26,117
20	50193400	BUSH	2			0,014	4	11	1		11,2385
21	_noorder	No single order	-								
22	_noorder	No single order	-								
23	50194400	ALL.SCR.M 6X 25	5	M 6 x 25 WN 11084-8.8 Zn		0,006	4	21	5		
24	03928600	SHIM 30X38X0,15	0... 2	30 x 38 x 0,15		0,001	1	21	2		4,186
25	50194300	CIRCLIP AK 30 X 1,5	2	A 30 x 1,5 K DIN 983		0,003	4	21	2		4,4135

Pos.	Part no.	Description	Qty.	Notice	Add. notice	kg	EA	TA	DA	dDPW	List price
26	50258500	O-RING 26 X1,5	2	26 x 1,5		0,001	4	11	1		1,729
27	01421102	CR-HANDLE SHAFT 275	1	275 mm		0,910	1	21	4		407,3615
27	01411402	CR-HANDLE SHAFT 200	1	200 mm		0,720	1	21	2		341,796
27	01469700	CR-HANDLE SHAFT 330	1	330 mm		1,350	1	21	4		391,3455
27	01187202	CR-HANDLE SHAFT 80	1	80 mm		0,410	1	21	2		277,6865
27	01426902	CR-HANDLE SHAFT 160	1	160 mm		0,670	1	21	4		342,4785
27	01426802	CR-HANDLE SHAFT 140	1	140 mm		0,585	1	21	2		328,3735
28	_nopart	Not in this engine	-								
29	01463600	GUIDING SHELL	1			0,200	1	21	1		126,1715
32	04020310	CRANK JAW LEFT	1			0,054	1	21	1		146,4645
33	03985300	GUARD	1			0,056	1	21	2		33,67
34	50195800	SHIM 10X16X1,0	1	10 x 16 x 0,5 DIN 988		0,001	4	11	1		1,4105
38	50134900	ALL.SCR.M 8X 16	2	M 8 x 16 DIN 6912-8.8 A3C		0,009	4	11	1		3,1395
39	50387100	CYL.PIN 5X20	1	5 M 6 x 20 DIN 6325		0,003	4	11	1		3,003
44	01459500	GUIDING SHELL	1	80 - 200 mm		0,274	1	21	2		148,239
44	01433300	GUIDING SHELL	1	200 - 265 mm		0,269	1	21	2		164,164
45	50183000	ALL.SCR. M 8X 35	2	M 8 x 35 DIN 912-8.8 A3C		0,018	4	11	1		1,547
46	50148100	FLAT WASHER 8,4	2	8,4 DIN 125-St A3C		0,002	4	11	1		0,455
47	50145900	FLAT WASHER 10,5	2	B 10,5 DIN 125-St A3C		0,004	4	11	1		1,4105
48	50327800	ALL.SCR.M10X 35	2	M 10 x 35 DIN 912-8.8 A3C		0,031	4	21	1		3,6855
49	03579700	SEALING RING	1			0,006	1	21	2		26,6175
50	04082900	CRANKING DEVICE	1	1/2"		0,066	1	21	2		70,0245
51	50387601	BUSH 1 INCH	1	1"		0,015	4	11	1		16,016
52	_noorder	No single order	-								
53	_noorder	No single order	-								
D	50223300	LOCTITE 221	-	50 ML		0,077	4	12	0		99,0535
K	50342600	GREASE START.DEVICE	-	100 GRAMM part was replaced by 50342601		0,100	0	12	0		



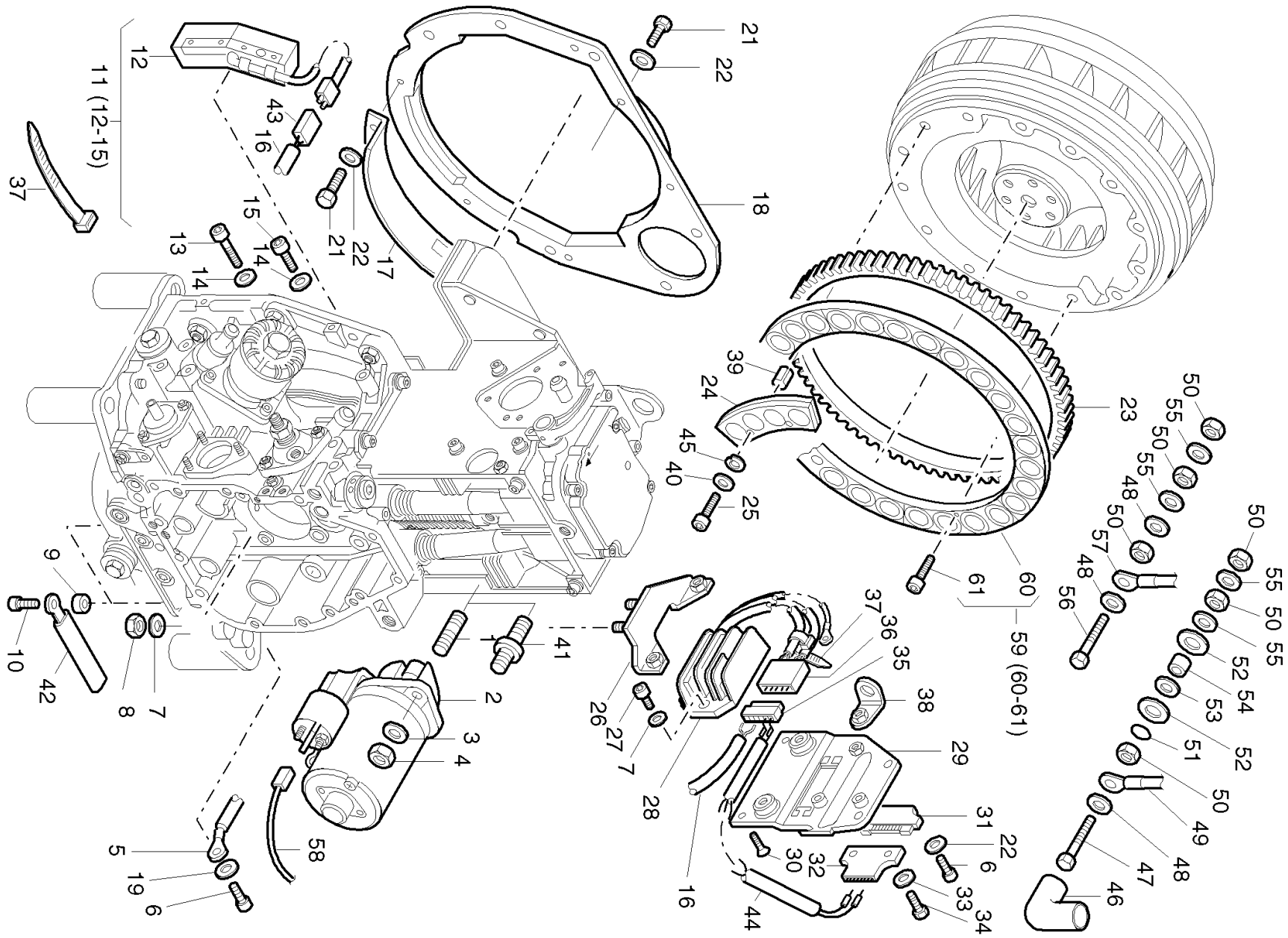

Pos.	Part no.	Description	Qty.	Notice	Add. notice	kg	EA	TA	DA	dDPW	List price
1	50201200	STUD M12X 50	2	M 12 x 50 DIN 835 - 8.8 A3C part was replaced by 50486400		0,055	0	21	7		
2	50385311	STARTER 24 V S/Z/C	1	24 V - 1,5 kW "S, Z, C" part was replaced by 50496100		7,070	0	21	0		
2	50385000	STARTER 12V T/U	1	12 V "T-U" part was replaced by 50385001		7,070	0	21	0		
2	50353420	EL.START. 12V S/Z/C	1	part was replaced by 50353421		0,000	0	21	7		
3	50093700	FLAT WASHER A 13	2	13 DIN 125-St A3C		0,006	4	11	1		1,729
4	50380600	HEXAGON NUT M 12	2	M 12 DIN 970-8 A3C		0,014	4	21	1		2,912
5	01459700	CLIP	2	part was replaced by 05001200		0,000	0	11	7		
6	50149100	ALLEN SCREW M 6X 12	2	M 6 x 12 DIN 912-8.8 A3C		0,005	4	11	1		1,092
7	50208500	SPRING WASHER 8	4	8 DIN 128 A3C		0,001	4	11	1		1,4105
8	50148000	HEXAGON NUT M 8	2	M 8 DIN 934-8 A3C		0,005	4	11	1		1,4105
9	04021000	BUSH 6,3X12X5	2	6,3 x 12 x 5		0,003	1	21	1		4,186
10	50170700	ALL.SCR.M 6 X 16	2	M 6 x 16 DIN 912-8.8 A3C		0,006	4	11	1		1,729
11	01592400	COIL WITH WIRE 12V	1	12 V		0,419	1	22	2		451,451
11	01592500	COIL WITH WIRE 24V	1	24 V		0,416	1	22	2		451,451
12	_nopart	Not in this engine	-								
13	50448800	ALL.SCR.M 6X 40	1	M 6 x 40 DIN 6912-8.8 A3C		0,010	4	11	1		3,2305
14	50144500	FLAT WASHER 6,4	2	6,4 DIN 125-St A3C		0,001	4	11	1		0,455
14	50165600	SPRING WASHER6,5X14	2	6,5 x 14 DIN 6904 A3C		0,001	9	11	0		0,455
15	50448700	ALL.SCR.M 6X 30	1	M 6 x 30 DIN 6912-8.8 A3C		0,007	4	21	1		2,3205
16	01462800	ELECTRIC WIRE	1			0,085	1	21	1		61,4705
17	04021100	PROTECT.ALTERNATOR	1			0,075	1	21	1		22,568
18	04009920	PARTING SHEET	1			0,270	1	21	1		95,7775
19	50144500	FLAT WASHER 6,4	1	6,4 DIN 125-St A3C		0,001	4	11	1		0,455
21	50165500	HEXSCREW M 6X 12	5	M 6 x 12 DIN 933-8.8 A3C		0,004	4	11	1		1,5015
22	50170900	SPRING WASHER 6	6	6 DIN 128 - A3C		0,001	4	11	1		0,455
23	03994200	GEARRING T/U	1			0,775	1	21	0		292,747
23	04021210	GEARRING S/Z/C	1			1,110	1	21	1		299,663
24	_nopart	Not in this engine	-								

Pos.	Part no.	Description	Qty.	Notice	Add. notice	kg	EA	TA	DA	dDPW	List price
25	_nopart	Not in this engine	-								
26	01440301	SUPPORT	1			0,104	1	21	5		
27	50165400	ALL.SCR.M 8X 16	2	M 8 x 16 DIN 912-8.8 A3C		0,009	4	21	1		2,6845
28	01425021	REGULATOR 24V	1	part was replaced by 01425022		0,295	0	21	7		
28	01248121	REGULATOR 12V	1	part was replaced by 01248122		0,050	0	21	7		
29	01440100	FASTENING PLATE	1			0,372	1	21	1		102,8755
30	50380800	CTR.SUNK SCR.M6X10	2	M 6 x 10 DIN 7991 -8.8 A3C		0,003	4	21	1		2,5935
31	50373700	PLUG SLEEVE HOUSING	1			0,005	4	21	1		16,835
32	50373600	PIN TERM.HOUS.6 WAY	1			0,007	4	21	1		16,835
33	50216300	WASHER 5,3	2	5,3 DIN 125-St A3C		0,001	4	11	1		0,455
34	50335700	HEXSCREW M 5X 25	2	M 5 x 25 DIN 933-8.8 A3C		0,005	4	11	1		1,4105
35	50402100	PLUG SLEEVE HOUSING	1	4-P.		0,003	4	21	1		26,2535
36	50402000	PLUG HOUSING 4-P.	1			0,002	4	21	1		26,2535
37	50358400	STRAP	4	200 x 4,8 mm SCHWARZ		0,001	4	11	1		0,6825
38	01440200	SUPPORT	1			0,022	1	21	1		13,013
39	_nopart	Not in this engine	-								
40	_nopart	Not in this engine	-								
41	_nopart	Not in this engine	-								
42	01470200	CLIP	2	part was replaced by 05023900		0,005	0	21	7		
43	50379700	PLUG HOUSING 2-P.	1			0,002	4	21	1		12,9675
44	01439400	WIRING HARNESS	1			0,020	1	21	1		93,821
45	_nopart	Not in this engine	-								
46	40026600	PROTECTION CAP	1			0,005	4	11	1		11,011
47	50400300	HEXSCREW M 8X 40	1	M 8 x 40 DIN 933-MS		0,020	4	21	1		8,6905
48	50179900	TOOTH.LOCK WASH.J 8	1...2	J 8,4 Zn DIN 6997 A3C		0,001	4	21	1		0,455
49	01430800	ELECTRIC WIRE B+	1	"Plus"		0,055	1	21	1		47,7295
50	50023000	HEXAGON NUT M 8	3	M 8 DIN 934-MS		0,005	4	11	1		2,6845
51	50426900	SERRATED WASH. A8,4	1	A 8,4 DIN 6798 A3C		0,001	4	21	1		0,455
52	03814100	INSULATING DISC	2			0,002	1	21	1		4,368
53	50426800	TOOTH.LOCK J 10,5	1	J 10,5 DIN 6797 A3C		0,001	4	21	1		0,455



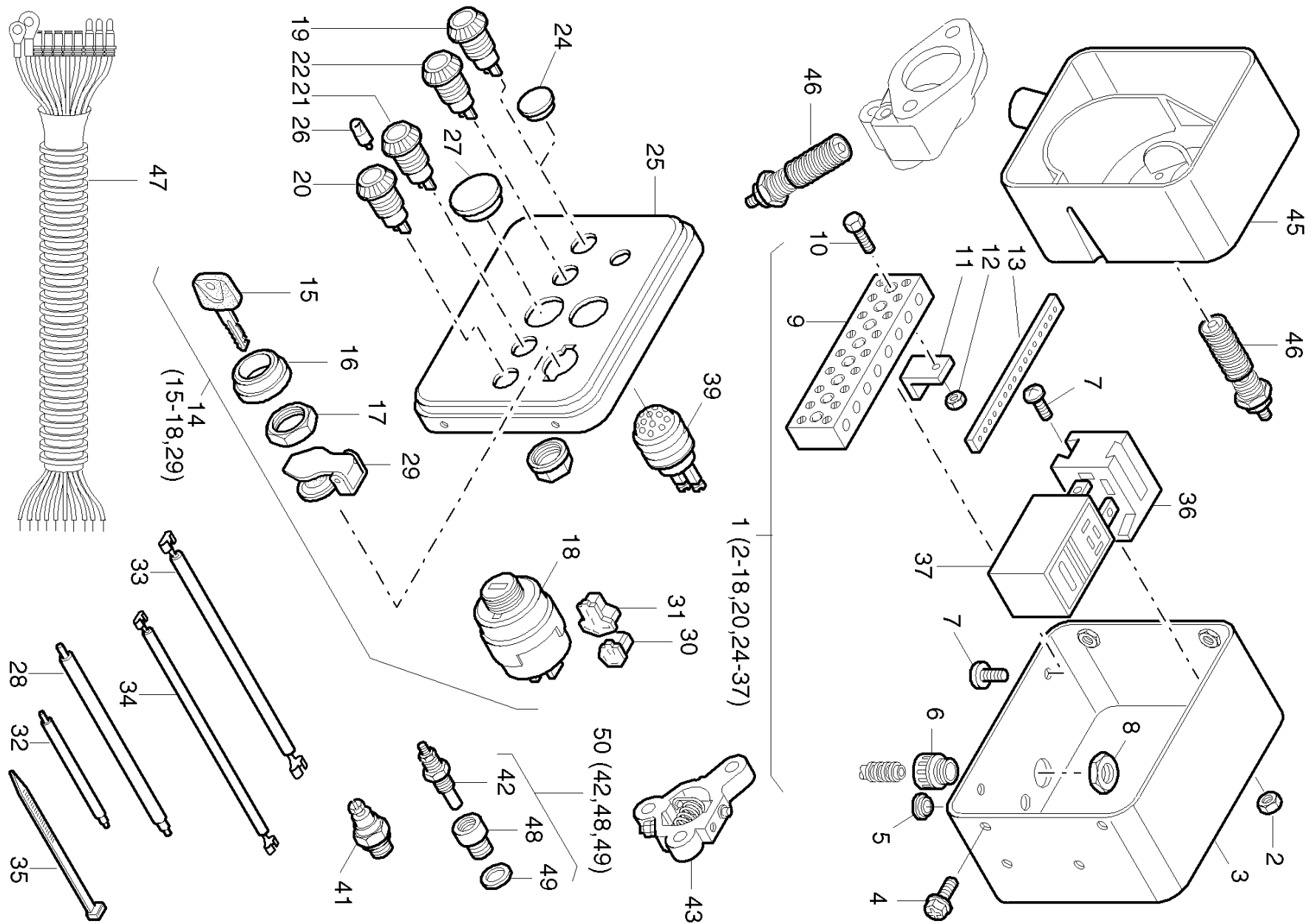

Pos.	Part no.	Description	Qty.	Notice	Add. notice	kg	EA	TA	DA	dDPW	List price
1	01407000	INSTRUMENT BOX 12V	1	12 V		1,740	1	21	5		1750,3395
1	01457700	INSTRUMENT BOX 24V	1	24 V		1,711	1	21	0		1892,6635
2	40028200	HEX.NUT M 5	1	M 5 DIN 980-8 C3A		0,002	4	11	1		2,6845
3	00716311	INSTRUMENT BOX	1			0,760	1	21	2		210,0735
4	50289200	HEXSCREW M 6X 12	4	M 6 x 12 KZ 1-8.8 A3D		0,005	4	11	1		1,8655
5	50160800	CLOSING PLUG 10MM	2	F 5 14x10,7x7,5 SCHW.		0,001	4	11	1		2,3205
6	50159011	MALE CABLE COUPLING	1	NH 13,5		0,010	4	21	2		26,2535
7	50049300	FILL.HEAD SCR.M5X10	3	M 5 x 10 DIN 7985-8.8 A3R		0,003	4	11	1		2,2295
8	50159100	HEXAGON NUT CE 13 M	1	CE 13 M		0,001	4	11	1		5,7785
9	50160700	CONNECTING BLOCK	1			0,150	4	21	2		78,169
10	50158800	ALL.SCR. M 4X 20	2	M 4 x 20 DIN 84 - 4.8 A3C		0,003	4	21	2		1,4105
11	03666700	BRACKET	2			0,015	1	21	2		12,3305
12	50147100	HEXAGON NUT M 4	2	M4 DIN 934 - 8 A3C		0,001	4	11	1		0,455
13	05004300	MARK	1			0,001	1	21	2		5,369
14	50276502	GLOW START.SWITCH	1			0,191	4	21	2		287,105
15	50345300	SWITCH BOX KEY	1	14603		0,004	4	12	1	P1	28,847
16	_noorder	No single order	-								
17	_noorder	No single order	-								
18	_noorder	No single order	-								
19	_nopart	Not in this engine	-								
20	50176500	INDICATOR LAMP BAT	1	BATT.		0,012	4	21	2		25,0705
21	50176600	INDICATOR LAMP OIL	1	OIL		0,012	4	21	2		25,0705
22	50176400	INDICATOR LAMP TEMP	1	TEMP.		0,012	4	21	2		25,0705
24	40096000	CLOSING PLUG	0... 3	F17 SCHW.		0,002	4	11	1		2,3205
25	03509211	FRONT PART	1			0,320	1	21	2		93,457
26	40009700	BULB 12V-2W	0... 4	12 V - 2 W		0,002	4	21	2		8,099
26	40009800	BULB 24V-2W	0... 4	24 V - 2 W		0,002	4	21	4		10,6925
27	40091400	CLOSING CAP	0... 2	F24 SCHW.		0,004	4	21	2		3,6855
28	01150101	DIODE CPL.	1			0,005	1	21	2		16,835
29	49050900	COVER	1			0,016	4	23	1		42,9065



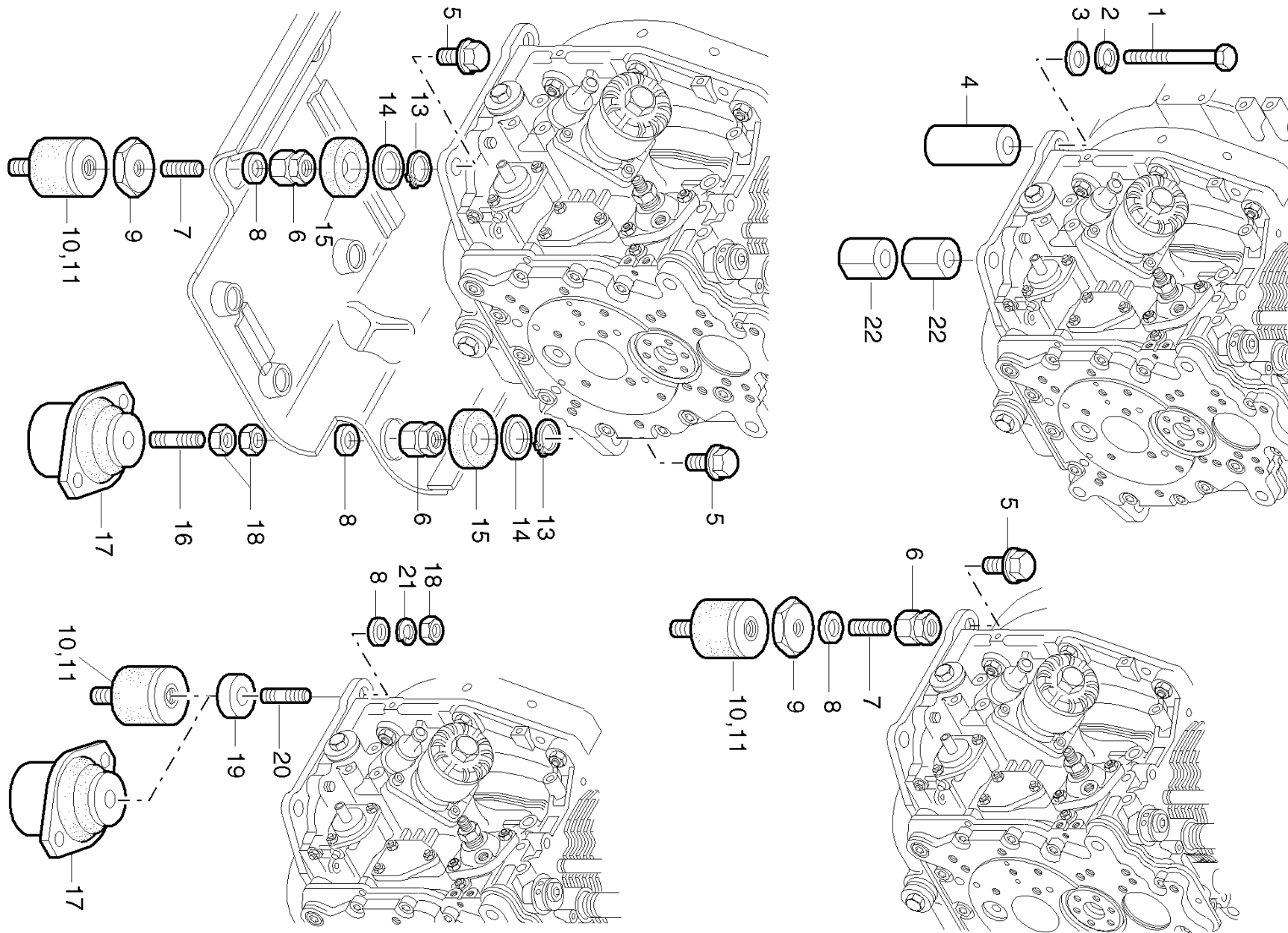



Pos.	Description	Notice
1	M10 x ... DIN 933 measure length	
2	SPRING WASHER 10	A 10 DIN 128
3	DISC 10,5	10,5 x 25 x 4 DIN 7349 A3C
4	BUSH 13X36X74,5	13 x 36 x 74,5
4	SPACER TUBE	13 x 36 x 10,5
5	HEXSCREW M10X 20	M 10 x 20 A3C W 158.12 - 10.9
6	HEXAGON NUT M10	M 10 x 25
7	GRUB SCREW M10X30	M 10 x 30
8	DISC 10,5	10,5 x 25 x 4 DIN 7349 A3C
9	DISC 10,5X55X5	10,5 x 55 x 5
10	ANTI VIBR.MOUNTINGS	40 Shore
11	ANTI VIBR.MOUNTINGS	55 Shore
13	CIRCLIP 24X1,2	A 24 x 1,2 DIN 471
14	WASHER 26,1X38X1	26,1 x 38 x 1
15	GASKET	46/16
16	GRUB SCREW M10 X 58	M 10 x 58
17	HYDRO BUFFER	V 12 / 600
18	HEXAGON NUT M 10	M 10 DIN 934-8 A3C
19	SPACER TUBE	13 x 36 x 10,5
20	STUD M10X 40	M 10 x 40 DIN 939
21	SPRING WASHER 10	10 DIN 128 A3C
22	SPACER DISC 10,5	f. Höhe 10,5, f. height 10.5 for hight 10,5
22	SPAC.SLEEV.74,5 MM	f. Höhe 74,5 f. height 74.5 for hight 74,5

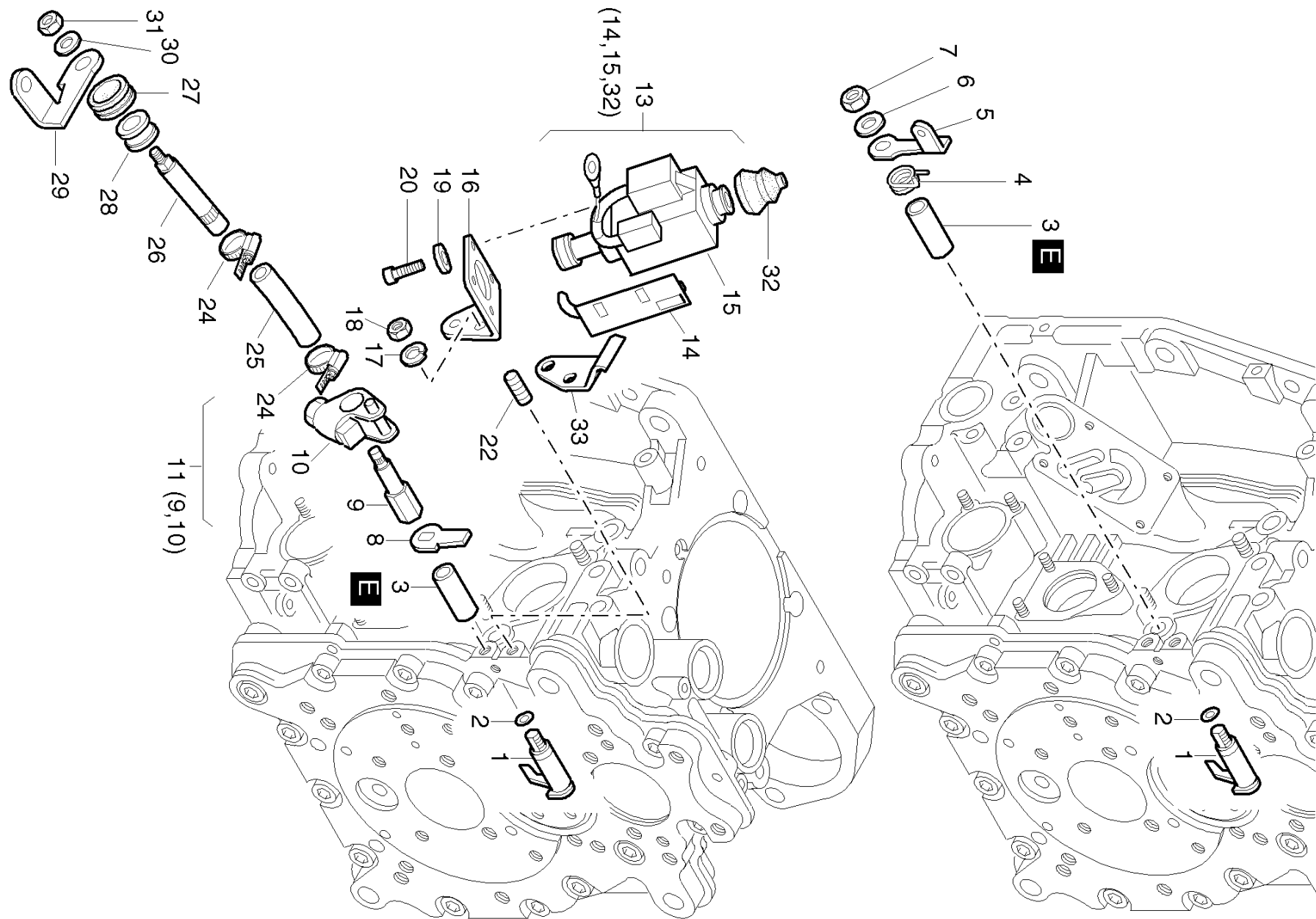

Pos.	Part no.	Description	Qty.	Notice	Add. notice	kg	EA	TA	DA	dDPW	List price
1	01254603	LEVER CPL.	1			0,020	1	21	5		
2	50343300	O-RING 4,6 X 1,85	1	4,6 x 1,85		0,001	4	21	1		1,092
3	04021400	BUSH	1			0,007	1	21	1		22,0675
4	04021800	SPRING	1			0,002	1	11	1		6,6885
5	04021700	LEVER	1			0,011	1	21	1		11,5115
6	50144500	FLAT WASHER 6,4	1	6,4 DIN 125-St A3C		0,001	4	11	1		0,455
7	50328300	HEXAGON NUT VM6	1	VM 6 DIN 980-8 A3C		0,002	4	11	1		1,4105
8	05015101	SUPPORT	1			0,005	1	21	2		19,7925
9	_noorder	No single order	-								
10	01493110	LEVER F.STOP MAGNT.	1	part was replaced by 01493111		0,015	0	21	7		
11	01515300	SHAFT+LEVER STOPMAG	1			0,035	1	22	2		53,1895
13	01515500	LIFTING MAGNET 12V	1	12 V		0,412	1	22	2		804,0305
13	01515400	LIFTING MAGNET 24V	1	24 V		0,412	1	22	2		804,0305
14	05058400	CABLE HOLDER	1			0,014	1	21	2		13,104
15	_noorder	No single order	-								
16	05023501	CONSOLE	1			0,039	1	21	2		17,5175
17	50170900	SPRING WASHER 6	2	6 DIN 128 - A3C		0,001	4	11	1		0,455
18	50144400	HEXAGON NUT M 6	2	M 6 DIN 934 - 8 A3C		0,002	4	11	1		1,2285
19	50216300	WASHER 5,3	3	5,3 DIN 125-St A3C		0,001	4	11	1		0,455
20	50112600	ALL.SCR.M 5X 10	4	M 5 x 10 DIN 6912-8.8 A3C		0,003	4	11	1		2,6845
22	50366800	STUD M 6X12	2	M 6 x 12 DIN 835-8.8 A3C		0,004	4	11	1		4,186
24	40037300	CLAMP 8-12	2	7,5 SKZ SGT 8-12		0,006	4	11	1		9,0545
25	03999001	FUEL HOSE 7 / 70	1	7 x 70		0,005	1	21	1		7,4165
26	03996600	SHAFT	1			0,035	1	21	1		75,985
27	03565400	RUBBER SLEEVE	1			0,003	1	11	1		5,8695
28	05069200	BUSH F.STOP SHAFT	1			0,005	1	21	1		19,838
29	04021700	LEVER	1			0,011	1	21	1		11,5115
30	50144500	FLAT WASHER 6,4	1	6,4 DIN 125-St A3C		0,001	4	11	1		0,455
31	50328300	HEXAGON NUT VM6	1	VM 6 DIN 980-8 A3C		0,002	4	11	1		1,4105
32	50248900	BELLOW	1			0,002	9	21	0		25,753



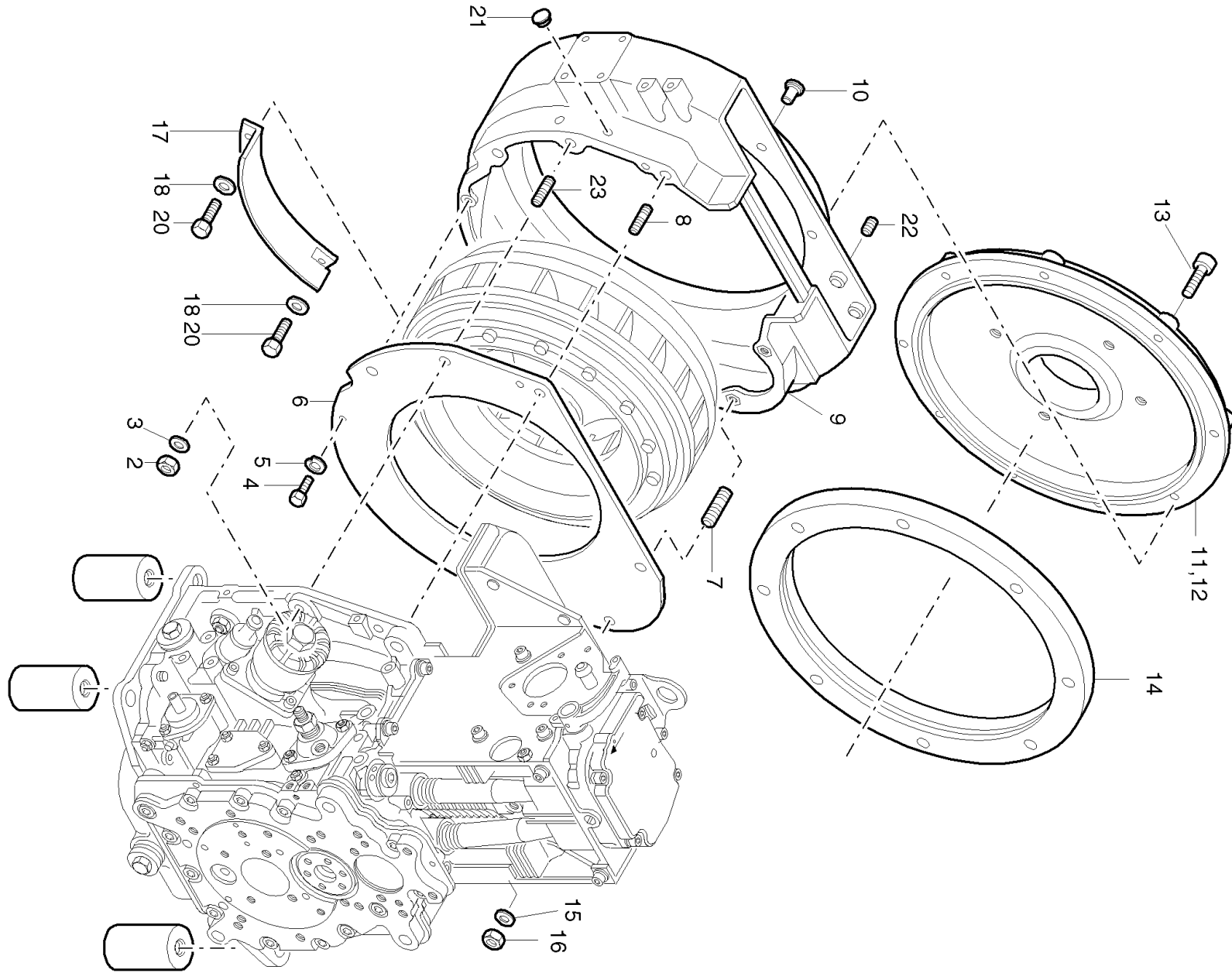



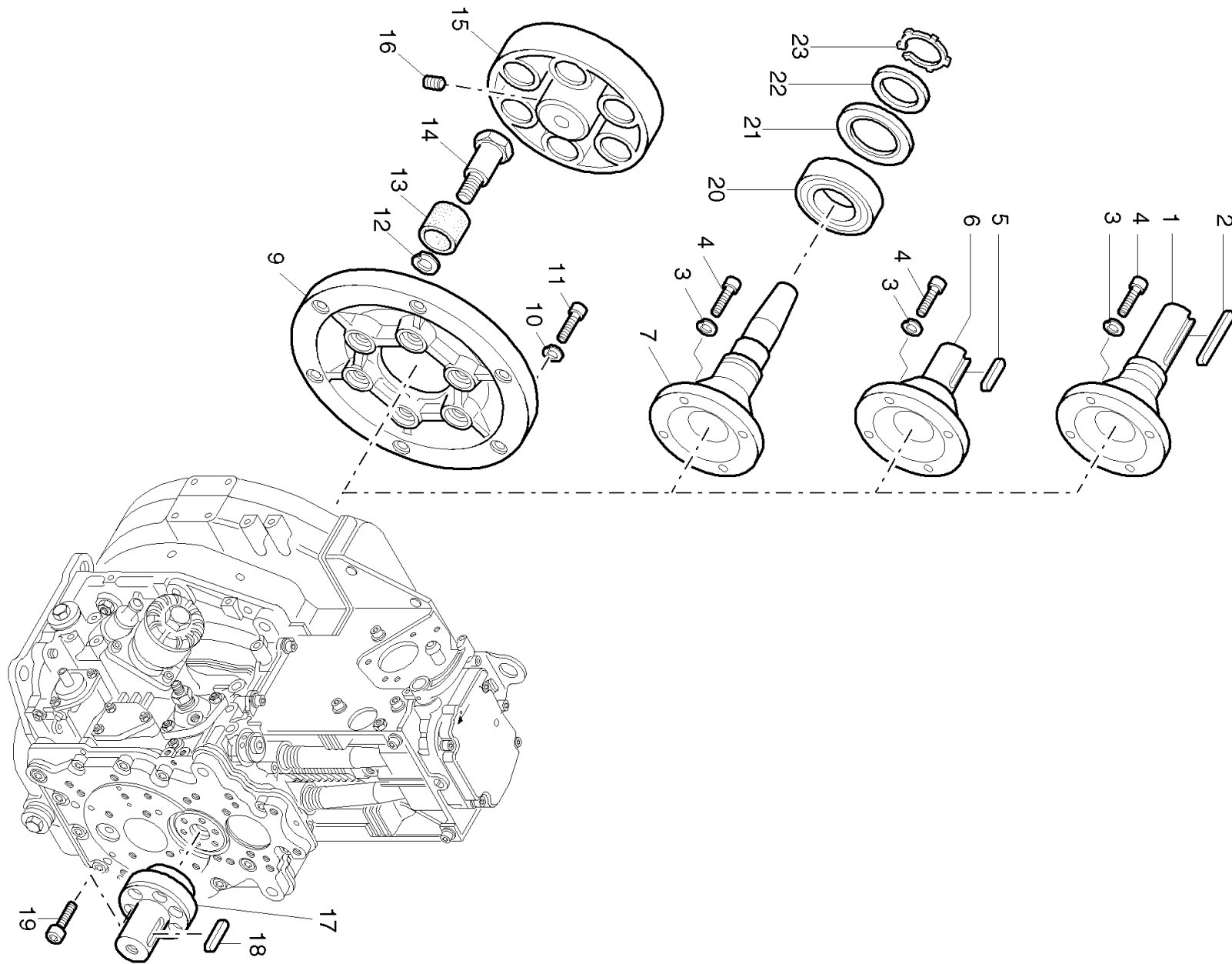

**\_090.24\_TA16 A16 Stubshaft, flexible coupling 1 D 80.24**

CD-ID: 001M1

Pos.	Part no.	Description	Qty.	Notice	Add. notice	kg	EA	TA	DA	dDPW	List price
1	03952001	SHAFT 25,4X161,0	1	2 ø 1" ZENTR.100		1,525	1	21	4		641,186
2	03962700	FITTINGKEY A6,35X63	1	A 6,35 x 63 part was replaced by 05141600		0,000	0	11	7		
3	50208500	SPRING WASHER 8	4	8 DIN 128 A3C		0,001	4	11	1		1,4105
4	50171500	ALL.SCR.M 8X 25	4	M 8 x 25 DIN 912-8.8 A3C		0,015	4	11	1		2,457
5	50011500	FITTINGKEY A 8X7X35	1	A 8 x 7 x 35 DIN 6885		0,014	4	21	2		3,367
6	03954300	SHAFT 30X100	1	2 ø 30 mm ZENTR.100		2,228	1	21	2		482,664
7	03953201	STUBSHFT.TAP.X177,5	1	4 (1") keg., con. ZENTR.100		1,580	1	21	2		561,743
9	03951700	FLANGE	1			1,850	1	21	4		331,331
10	50208500	SPRING WASHER 8	6	8 DIN 128 A3C		0,001	4	11	1		1,4105
11	50366300	ALL.SCR.M 8X 20	6	M 8 x 20 DIN 912-8.8 A3C		0,013	4	11	1		2,3205
12	50061601	SPRING WASHER 12	6	VHZ 12		0,002	4	21	2		1,2285
13	03151000	RUBBER SHELL	6	SCHLAUCHST		0,015	1	21	2		13,5135
14	03046900	TAPPET	6			0,090	1	21	2		34,9895
15	03004602	COUNTER FLANGE	1			2,270	1	21	4		554,372
16	50004600	GRUB SCREW M 8X16	1	M 8 x 16 DIN 916-45H A3C		0,003	4	11	1		2,912
17	05007400	STUBSHAFT 25X65	1	25 x 65 ZENTR. 30		0,500	1	21	4		634,452
18	50011500	FITTINGKEY A 8X7X35	1	A 8 x 7 x 35 DIN 6885		0,014	4	21	2		3,367
19	50170700	ALL.SCR.M 6 X 16	6	M 6 x 16 DIN 912-8.8 A3C		0,006	4	11	1		1,729
20	50015000	GROOV.BALLBEAR.6307	1	6307 DIN 625 FABR.URB		0,444	4	21	2		127,9915
21	50354200	NILOS RING 6307 ZAV	1	6307 ZAV		0,009	4	21	2		25,662
22	50354300	SPACER RING	1	A 35		0,010	4	21	2		19,2465
23	50354400	CIRCLIP AL 35X1,5	1	AL 35 x 1,5		0,004	4	21	2		11,648



